

## USE AND MAINTENANCE MANUAL



## AIRCOOLED EVAPORATING UNITS MEE - MEH



## TABLE OF CONTENTS

1. INTRODUCTION .....	pag. 2
1.1 Manual content .....	pag. 2
1.2 Safety marks .....	pag. 2
1.3 Referring standards .....	pag. 2
1.4 Warranty .....	pag. 2
1.5 Readers of the Manual .....	pag. 3
2. MAIN SAFETY RULES .....	pag. 3
2.1 Main warnings .....	pag. 3
2.2 Allowed use .....	pag. 3
2.3 Forbidden use .....	pag. 3
2.4 Dangerous areas .....	pag. 4
3. GENERAL DESCRIPTION .....	pag. 4
3.1 MEE - MEH features .....	pag. 4
3.2 Main components .....	pag. 5
3.3 Cooling circuit .....	pag. 7
3.4 Technical specification .....	pag. 9
3.5 Dimensional drawings .....	pag. 9
3.6 Main accessories .....	pag. 12
4. INSTALLATION .....	pag. 13
4.1 Identification tag .....	pag. 13
4.2 Reception and inspection .....	pag. 13
4.3 Handling .....	pag. 14
4.4 Arrangements and placing .....	pag. 17
4.5 Cooling connections .....	pag. 19
4.6 Vacuum and charge execution .....	pag. 20
4.7 Hydraulic connections.....	pag. 22
4.8 Electric connections .....	pag. 25
5. OPERATION .....	pag. 30
5.1 First check .....	pag. 30
5.2 First startup .....	pag. 30
5.3 Microprocessor setting .....	pag. 30
5.4 Fault alarm and display system .....	pag. 31
5.5 Troubleshooting .....	pag. 31
5.6 Routine maintenance .....	pag. 33
5.7 Precautionary planned maintenance .....	pag. 36
5.8 Special Maintenance Operations .....	pag. 42
6. DEMOLITION .....	pag. 44
7. REMOTE CONDENSER .....	pag. 45

## 1. INTRODUCTION

### 1.1 Manual content

The present handbook, originally written in Italian, was completed in compliance with the "Machinery Directive". It contains all the necessary information for carrying out without any risk transportation, installation, startup, operation, setting, maintenance and dismantling of the evaporating units of series MEE / MEH.

Should you have any doubt on the correct understanding of these instructions, please contact the Manufacturer in order to get further explanations.

### 1.2 Safety marks

The following safety marks are used in this manual to draw attention to all useful information in order to avoid any dangerous situation which could be unsafe and harmful for people, could damage equipment and environment besides breaking the unit.



It means operation and behaviour not allowed.



It means danger or risk to people, things or environment.



It means an electrical danger.



It means a warning about important functions or useful information. Pay the maximum attention to the paragraphs marked with this symbol.

### 1.3 Referring standards

The units of MEE / MEH series are designed and manufactured in compliance with the relevant European Directives and in particular, they meet the "Essential Safety Requirements" as set out in the European Directive 89/392/CEE, and further amendments, as attested by the CE mark that is on each unit.

As a matter of fact, the units are certified by the manufacturer and are provided together with the CE Declaration of Conformity which is attached to the present manual.

Where applicable, the units mentioned in this handbook are in conformity with the directive 97/23/CE (PED), concerning the pressure devices.

### 1.4 Warranty

The manufacturer warrants the air cooled water chillers and heat pumps according to what stated on his general sales terms or according to what else explicitly agreed.

The Manufacturer Warranty is void in case the guidance of this manual has not been carefully respected.

The manufacturer refuses all responsibility for any damage to people, animals, things or environment, caused by incorrect installation, maintenance or setting or misuse of the machine. It is considered as "misuse" of the machine any use not explicitly allowed in this manual.



Warning: on the first startup, duly fill in the relevant report attached to this manual and send a copy to Emicon A.C. (Customer Service), in order to make the warranty valid.

## 1.5 Readers of the Manual

This manual and all its attachments are supplied with the described unit.

The manual must be kept by the machine's owner in a proper place. To this end, a plastic bag where to store the manual has been placed inside the machine so that it can be always easily accessible for consultation and at the same time, it can be preserved in a good state. All people authorized to operate with the unit, in particular, all technicians assigned to the unit maintenance, must know all information and instructions contained in this manual

In case the manual is lost or deteriorated, a new copy must be requested directly to the manufacturer

## 2. MAIN SAFETY RULES

### 2.1 General warnings



Read carefully the whole handbook before performing any operation on the unit. Only qualified and trained technicians must perform any operation on the machine.



Do not touch the machine if with bare feet or with humid or wet parts of the body.

Do not perform any cleaning operation before the main switch is "OFF" and power line disconnected.

Do not spread, leave unattended or to the reach of children any packaging material (carton box, staples, plastic bags, etc.) as they may be a source of danger.

### 2.2 Allowed use

MEE - H: Evaporating units with remote air condensation intended for watercooling in air-conditioning and/or industrial systems. They are designed for internal installation.

### 2.3 Forbidden use

Do not use the machine:

- Ø For other use than that described in paragraph 2.2;
- Ø When it is exposed to rainfall, especially when the unit is designed for internal installation;
- Ø in atmosphere with high risk of fire or explosion;
- Ø in spaces with corrosive atmosphere;
- Ø to heat or cool aggressive fluids for copper, carbon steel and stainless steel.



Any operation on the unit must be carried out in compliance with local technical standards.

### 2.4 Dangerous areas

On the unit there are dangerous areas for electric risk and hot temperatures.

The unit can be closed by case panels; in this case the dangerous parts inside the unit are not accessible from outside. Only qualified and trained personnel can remove the covering panels. The unit is supplied with the cooling circuit already charged with pressure gas and therefore it is necessary to pay the maximum attention in order to avoid accidental release of the gas in the atmosphere.

## 3. GENERAL DESCRIPTION

### 3.1 Characteristics of the units MEE-H

The units of series MEE-H are supplied with nitrogen charge and anti-freeze oil pre-charged in the compressor; they are electrically tested at the factory.

Interpreting key for the initials used to mark the units:

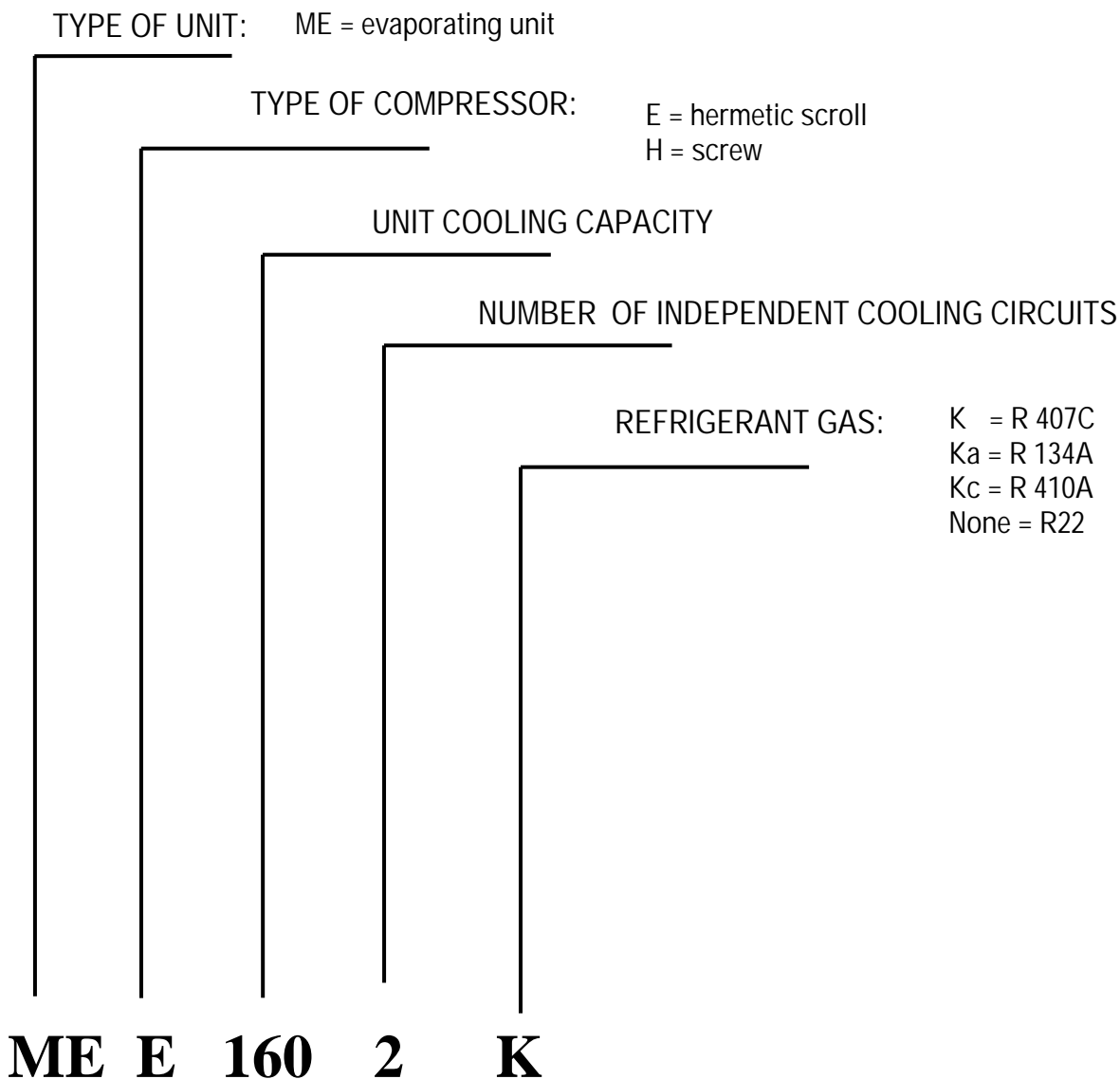

## 3.2 Main components

The units of MEE / MEH series are made of the following main components:

- Ø Housing in painted steel plates or support frame made of bent and painted steel profiles;
- Ø Compressors, installed on rubber vibration dampers and equipped with oil sump heater,
- Ø Weld-brazed plate evaporator or shell & tube evaporator with heat insulation;
- Ø Cooling circuit composed of: thermostatic expansion valve, sight glass, dehydrating filter, safety device, anti-freeze thermostat, high and low pressure switches;
- Ø Electric panel in compliance with CE norms and provided with main disconnecting switch; thermal and amperometric protections, contactors, auxiliary low voltage circuit, terminal board;
- Ø The control microprocessor allows to manage the unit operation and its alarms.

### ATTENTION !

Since the safety valve must be installed on the high pressure circuit, it must be installed by the person completing the circuit; it is not supplied or installed separately.

### MEE single circuit

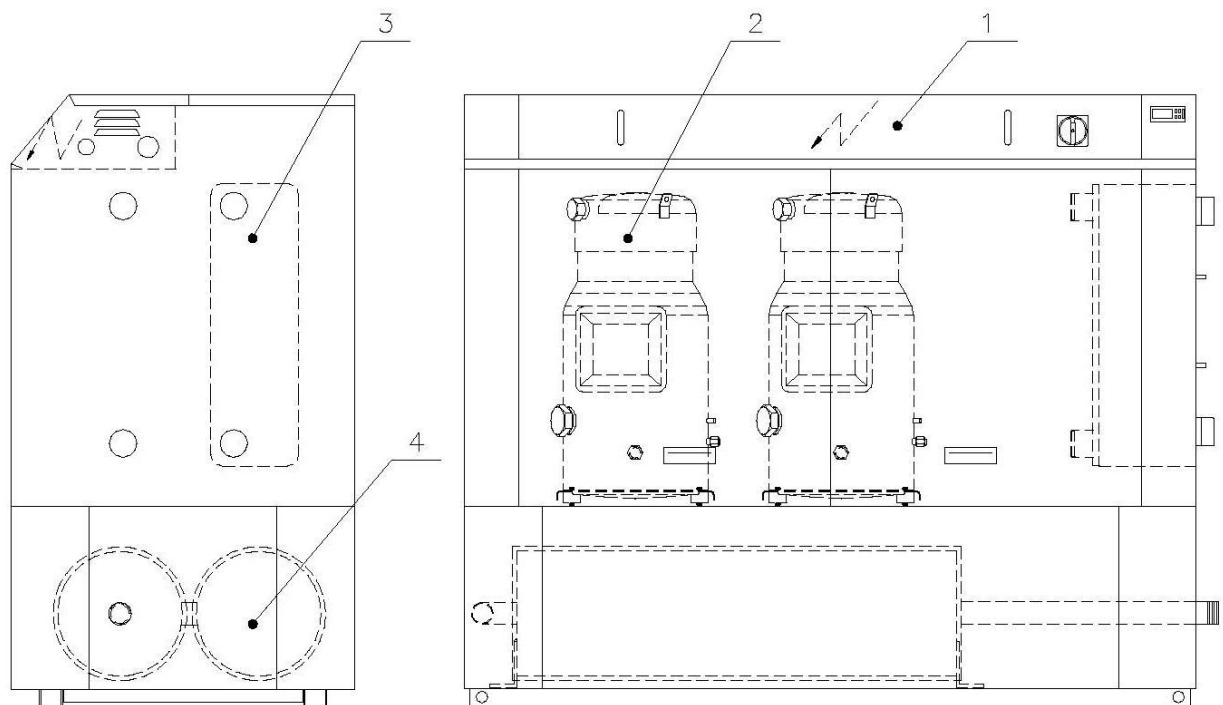

Pict. 1

MEE multicompressor

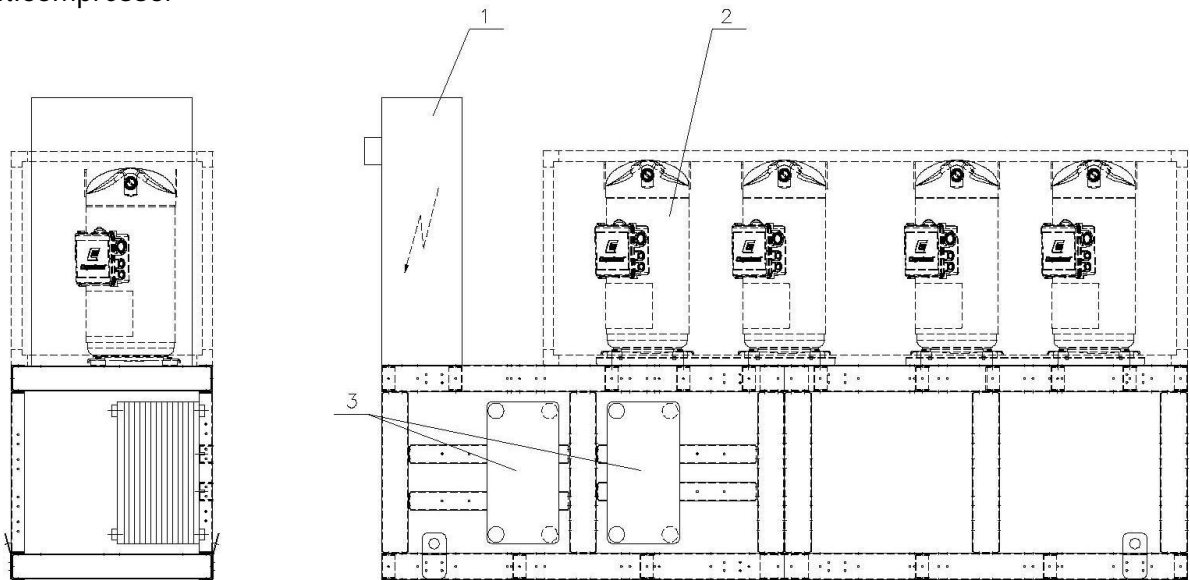

Pict. 2

MEH mono/multicompressor

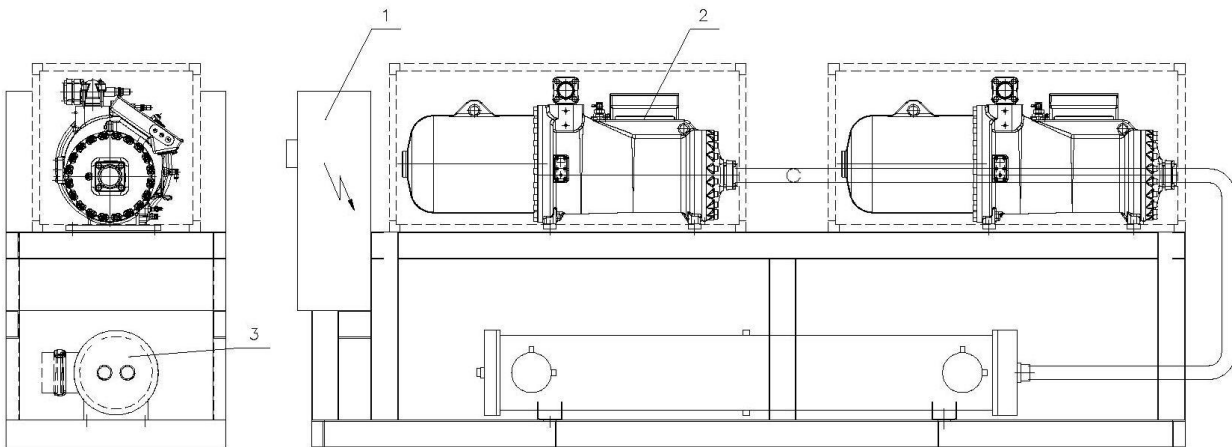

Pict. 3

Key

- 1) Electric panel
- 2) Compressor
- 3 Evaporator
- 4 Tank



3.3 Cooling circuit

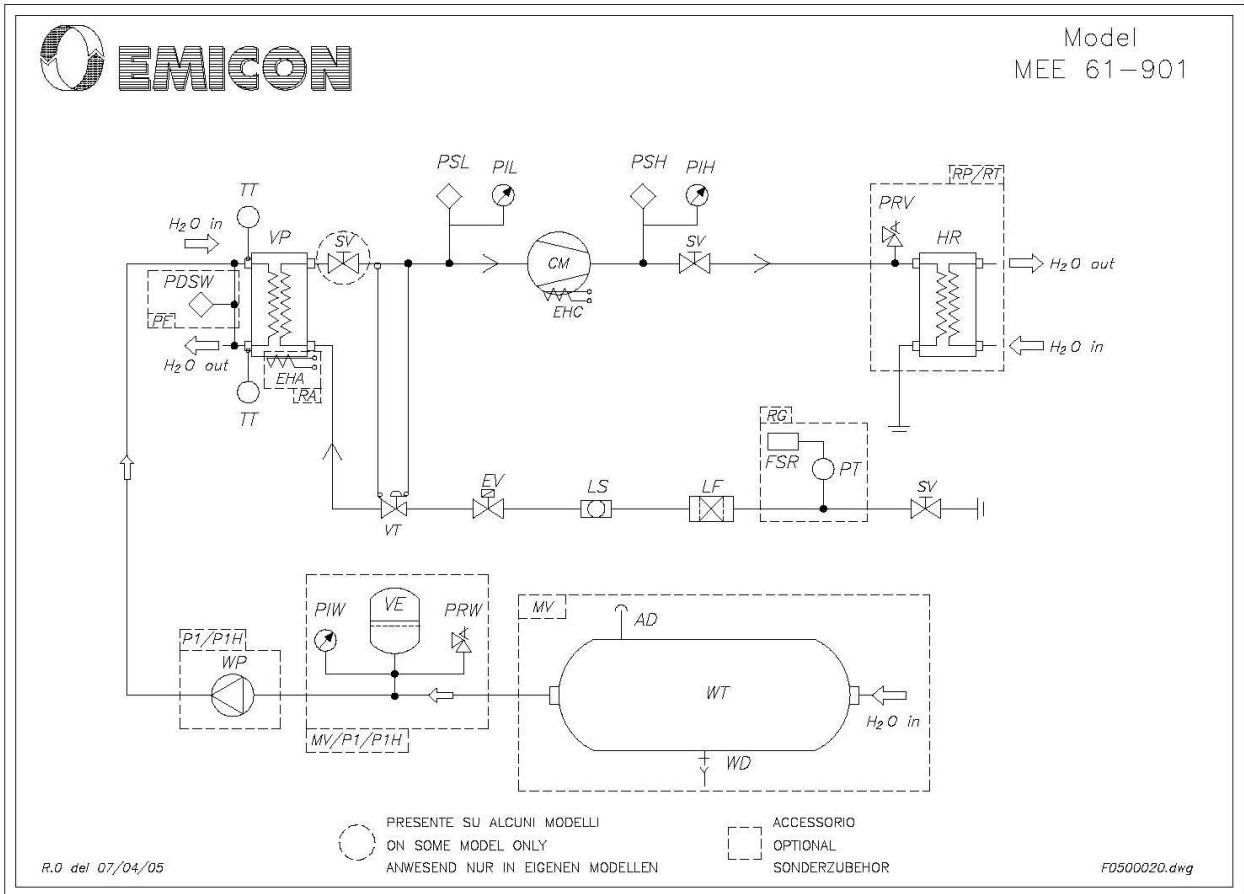

Pict. 4

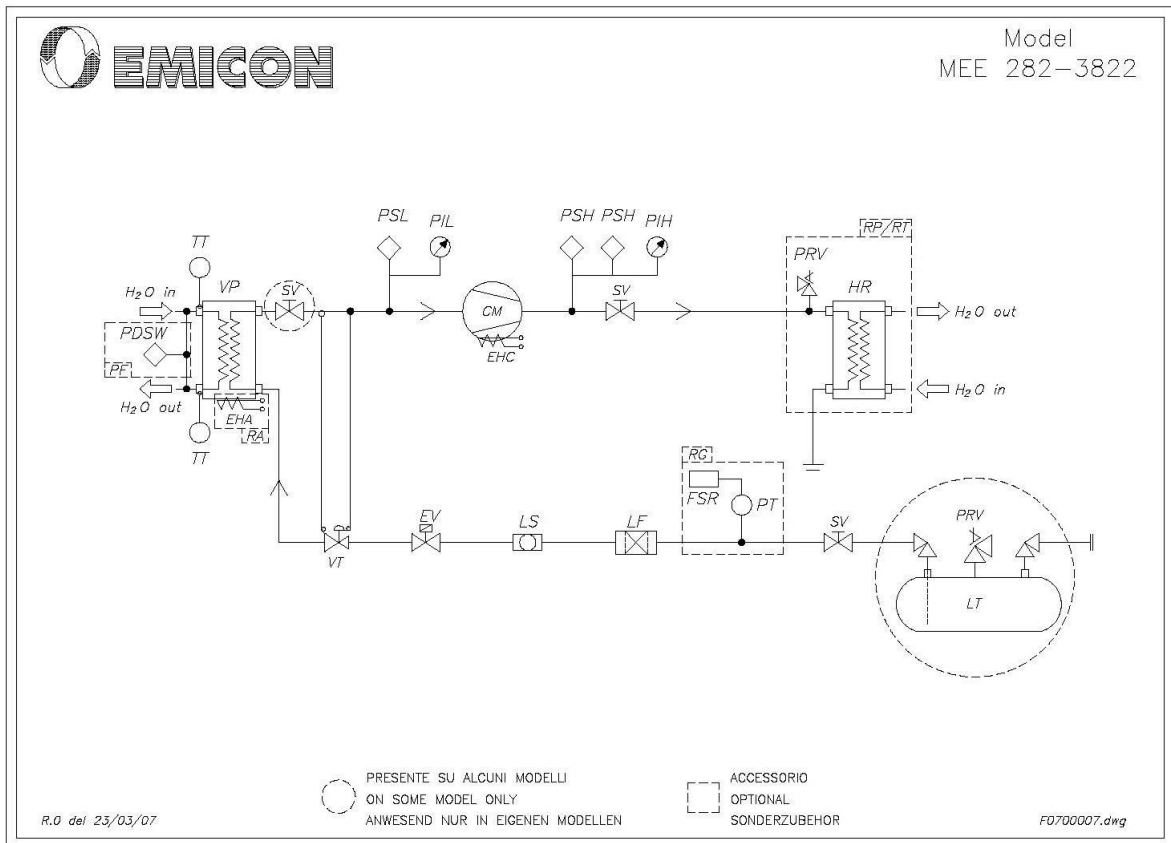

Pict. 5

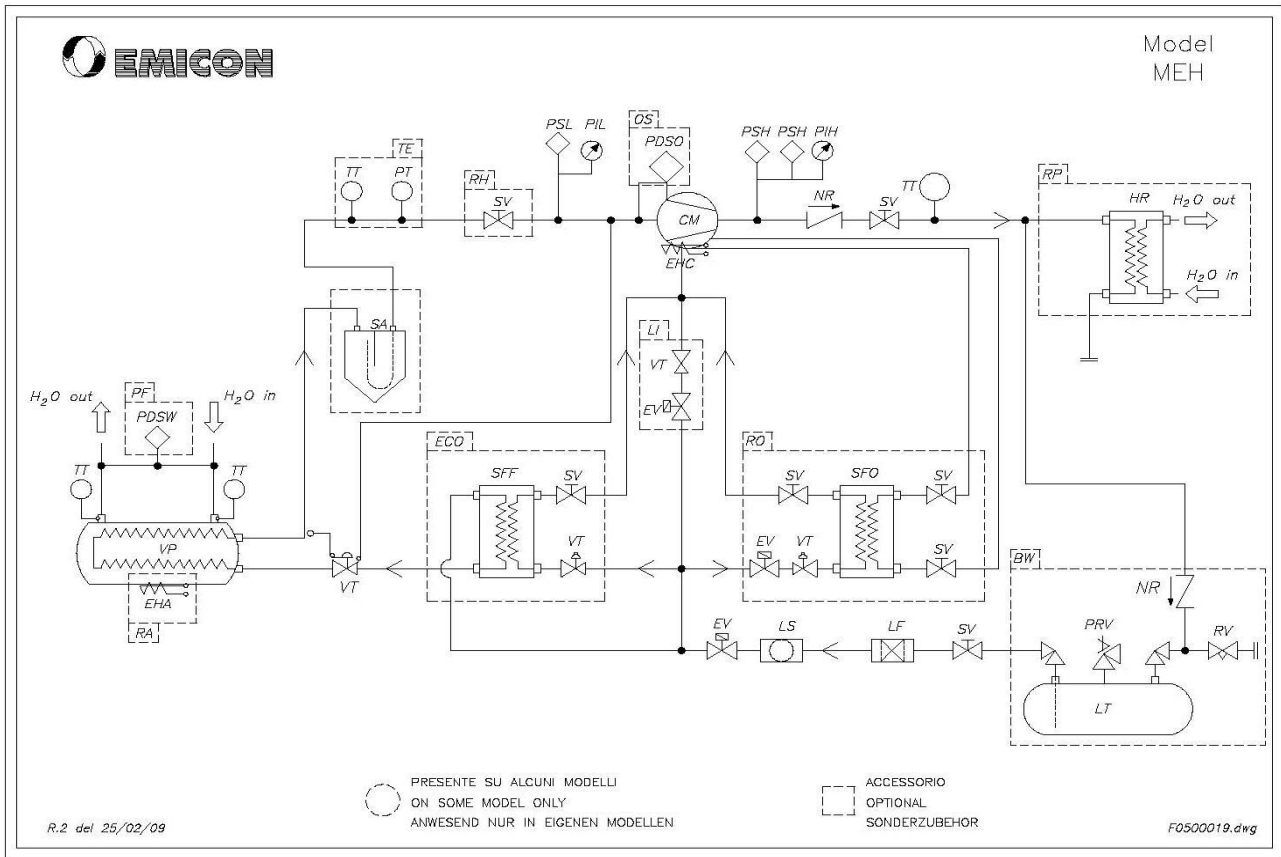

Pict. 6

Cooling circuit keys

<b>AC</b>	AIR HEAT EXCHANGER	<b>PDIO</b>	OIL GAUGE	<b>VE</b>	EXPANSION VESSEL
<b>AD</b>	AIR DISCHARGE VALVE	<b>PDSO</b>	OIL LEVEL PRESSOSTATIC VALVE	<b>VP</b>	EVAPORATOR
<b>AV</b>	VIBRATION DAMPER	<b>PDSW</b>	DIFFERENTIAL WATER SWITCH	<b>VT</b>	THERMOSTATIC EXPANSION VALVE
<b>CM</b>	COMPRESSOR	<b>PIH</b>	HIGH PRESSURE GAUGE	<b>WC</b>	WATER COIL
<b>CO</b>	CONDENSER	<b>PIL</b>	LOW PRESSURE GAUGE	<b>WD</b>	WATER CHARGE AND DISCAHRGE VALVE
<b>CT</b>	CONDUCTIVITY PROBE	<b>PIW</b>	WATER VALVE	<b>WE</b>	WATER EXCHANGER
<b>EF</b>	FAN	<b>PRV</b>	OVERPRESSURE DISCHARGE DEVICE	<b>WF</b>	WATER FILTER
<b>EHA</b>	ANTIFREEZE HEATER	<b>PRW</b>	SAFETY WATER FLOW SWITCH	<b>WP</b>	WATER PUMP
<b>EHC</b>	CRANK-CASE HEATER	<b>PSH</b>	HIGH PRESSURE SWITCH	<b>WT</b>	WATER BUFFER TANK ACQUA
<b>EV</b>	SOLENOID VALVE	<b>PSL</b>	LOW PRESSURE SWITCH	<b>BG</b>	HOT GAS COIL
<b>FSR</b>	FAN SPEED REGULATOR	<b>PT</b>	PRESSURE TRANSDUCER	<b>YVCA</b>	HUMIDIFIER FILL VALVE
<b>FWV</b>	4-WAY VALVE	<b>RE</b>	ELECTRIC HEATER	<b>YVSA</b>	HUMIDIFIER DRAIN VALVE
<b>H</b>	HUMIDIFIER	<b>RV</b>	MODULATING VALVE		
<b>HR</b>	HEAT RECOVERY	<b>SA</b>	LIQUID SEPARATOR		
<b>HT</b>	HUMIDITY PROBE	<b>SFF</b>	FREON - FREON HEAT EXCHANGER		
<b>LF</b>	DEHYDRATING FILTER	<b>SFO</b>	FREON - OIL HEAT EXCHANGER		
<b>LS</b>	SIGHT GLASS	<b>SL</b>	NOISE LEVEL REDUCER		
<b>LT</b>	LIQUID RECEIVER	<b>SO</b>	OIL SEPARATOR		
<b>NR</b>	NON-RETURN VALVE	<b>SV</b>	SHUT-OFF VALVE		
<b>OF</b>	OIL FILTER	<b>TS</b>	SAFETY THERMOSTATIC VALVE		
<b>OLR</b>	OIL LEVEL REGULATOR	<b>TT</b>	TEMPERATURE PROBE		
<b>OT</b>	OIL RESERVE	<b>TWV</b>	3-WAY VALVE		

### 3.4 Technical specification

The main technical features of the units are shown in the attachments.

### 3.5 Dimensional drawings

MEE single circuit

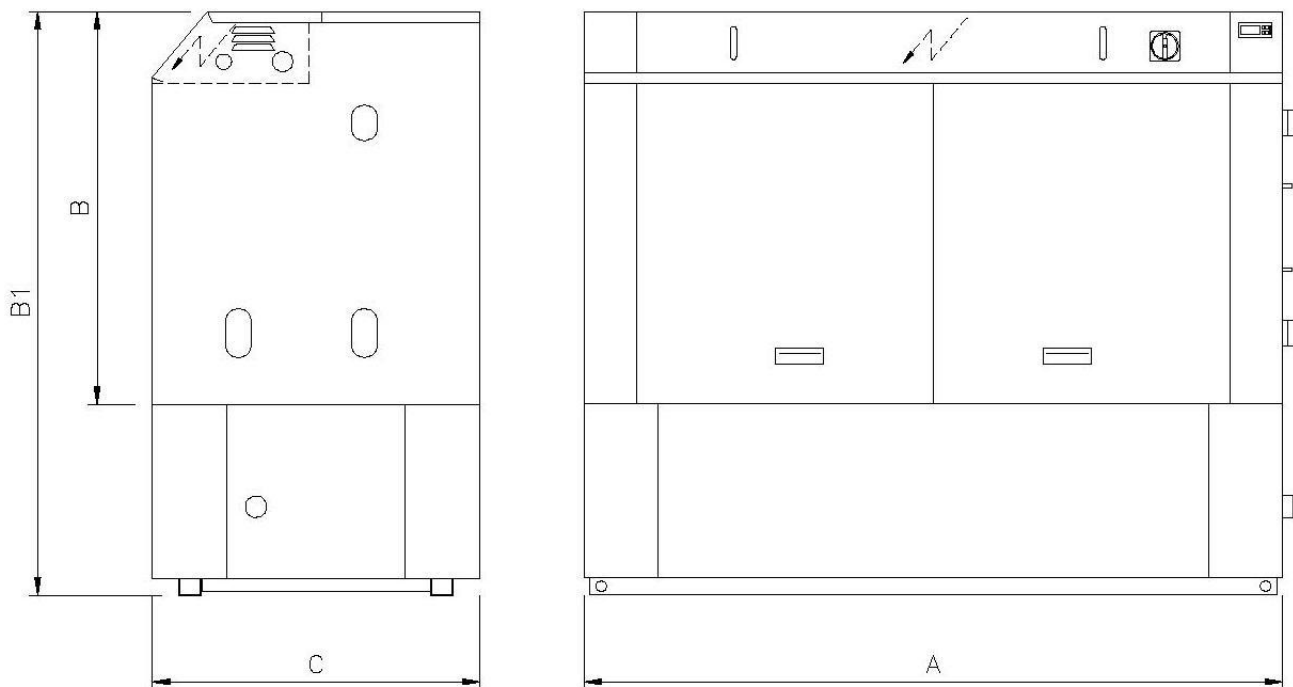

Pict. 7

Modello MEE	Tipo gas	A	B	B <sub>1</sub> *	C
61-111-171-201-221-251-301-381-461	K (R407C)	800	960	1430	500
501-571-751-901	K (R407C)	1600	960	1340	750
151-181-211-271-311	Ka (R134A)	800	960	1430	500
351-421- 521-601	Ka (R134A)	1600	960	1340	750
61-111-161-191-221-271-311-391-461	(R22)	800	960	1340	500
521-601-771-901	(R22)	1600	960	1430	750

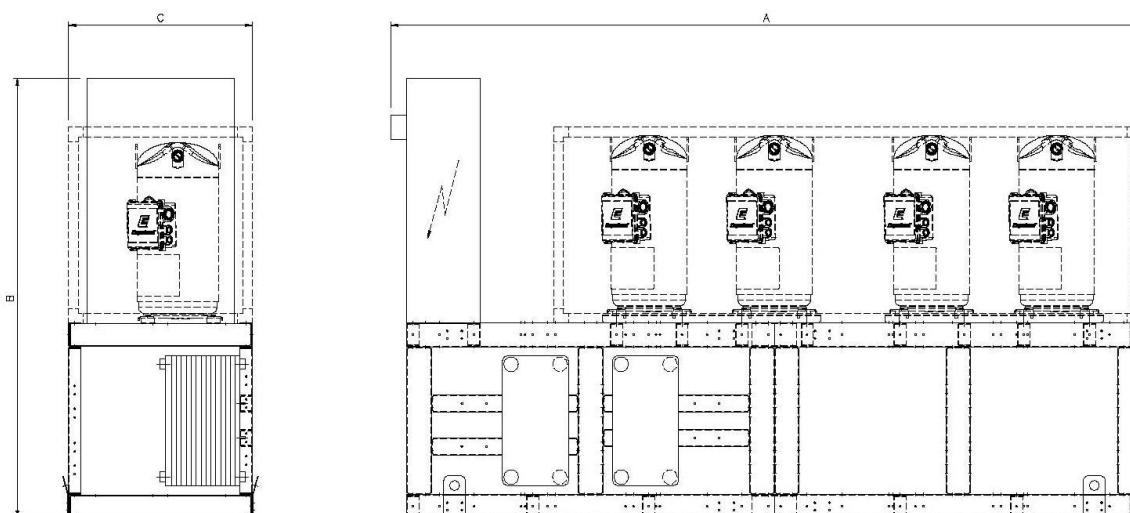

Pict. 8

Modello MEE multicompressore	Tipo gas	A	B	C
541-631-761-931-442-532-612-762-922	K (R407C)	1500	1600	750
1201-1501-1901-1232-1552-1912	K (R407C)	1500	1800	750
892-1082-1212-1512-1852	K (R407C)	2500	1800	750
2462-3102-3822	K (R407C)	3000	1800	750
341-401-491-591-282-352-402-492-592	Ka (R134A)	1500	1600	750
711-971-1201-772-972-1222	Ka (R134A)	1500	1800	750
572-702-802-992-1192	Ka (R134A)	2500	1800	750
1522-1952-2442	Ka (R134A)	3000	1800	750
531-611-741-891-422-522-602-742-892	(R22)	1500	1600	750
1171-1451-1811-1172-1452-1812	(R22)	1500	1800	750
842-1052-1232-1482-1792	(R22)	2500	1800	750
2352-2922-3632	(R22)	3000	1800	750

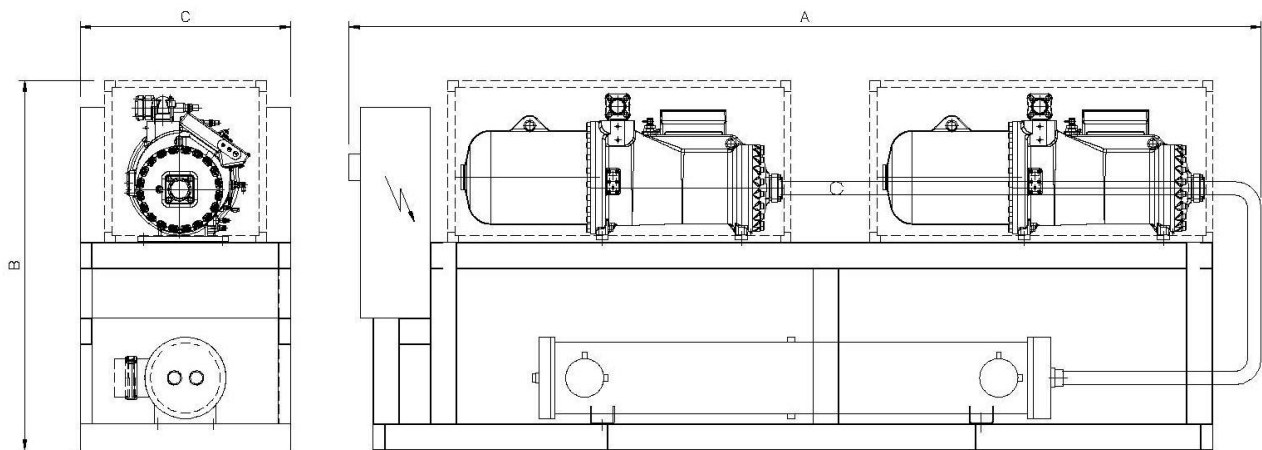

Pict. 9

\* Dimension including option CFU

Modello MEH mono-multicompressore	Tipo gas	A	B *	C
131-161-191	K (R407C)	2430	1525	800
211-241	K (R407C)	2430	1610	850
301-341	K (R407C)	3310	1525	800
391	K (R407C)	3340	1610	850
531-611-691-731-831-	K (R407C)	3700	1900	1300
252-312	K (R407C)	3750	1790	750
372-422-472	K (R407C)	3860	1840	900
592-672-772	K (R407C)	3990	1990	1000
1062-1222-1392-1462-1652	K (R407C)	5200	1300	2450
1933-2203-2493	K (R407C)	5200	2450	2000
91-111-131-151-171	Ka (R134A)	2430	1525	800
211-241-271-321-361	Ka (R134A)	3350	1525	850
421-481-541-621	Ka (R134A)	3700	1900	1300
182-222	Ka (R134A)	3750	1710	750
252-292-332	Ka (R134A)	3860	1790	900
412-472	Ka (R134A)	3860	1840	900
542-642-732	Ka (R134A)	3990	1990	1000
842-972-1092-1232	Ka (R134A)	5200	2450	1300
1253-1453-1633-1793	Ka (R134A)	5200	2450	2000
131-161-191-221-251	(R22)	2430	1530	800
311-361-411	(R22)	3350	1525	850
551-641-731-811-911	(R22)	3700	1900	1300
262-322	(R22)	3750	1710	750
382-442	(R22)	3860	1790	900
502	(R22)	3860	1840	900
622-702	(R22)	3990	1990	1000
812	(R22)	3990	2030	1000
1102-1282-1462-1632-1832-	(R22)	5200	2450	1300
1903-2193-2433-2753	(R22)	5200	2450	2000

### 3.6 Main accessories

A: Amperometer

AE: Power supply different from the nominal power.

AC: Azionamento elettrico compressori

CI: Capottino insonorizzazione compressori

CF: Soundproofed compressors cabinet with standard material

CFU: Soundproofed compressors cabinet with lead material or similar

CL: Soundproofed compressors cabinet with standard material (model RWE monocircuit)

CM: Soundproofed compressors cabinet with lead material or similar (model RWE monocircuit)

CS: Compressor inrush counter

DQ: Additional box for connection of power supply cables (for units with screw compressors)

DS: Star/Delta compressors startup (units with screw compressors)

HG: Hot gas by-pass.

IE: Fumigated wooden crate packing.

IG: Watch card

IH: Serial interface RS485.

IM: Seawood packing

IR: Packing with fumigated wooden pallet and transparent film

LI: Liquid injection (units with screw compressors)

KS: Lifting kit

MF: Phase monitor

MP: Oversized Microprocessor

MT: High and low pressure gauges

MV: Buffer tank; it is composed of: water tank, expansion vessel, safety valve, hydrometer, water charge and discharge valve, air discharge valve

M12: Modulating capacity control for 2-circuit units

M25: Modulating capacity control for 1-circuit units

PA: Rubber vibration dampers

PF: Safety water flow switch

PM: Spring-type vibration dampers

PW: Part-winding compressors startup

PQ: Remote microprocessor

P1: Pump group; expansion vessel, safety valve, hydrometer, water charge and discharge valve, air discharge valve.

P1H: Higher head pressure pump group; expansion vessel, safety valve, hydrometer, water charge and discharge valve, air discharge valve.

RA: Antifreeze heater on evaporator.

RF: Power factor correction system  $\cos \varphi = 0,9$

RH: Shut-off valve on compressor suction side

RL: Compressors overload relays.

RP: Partial heat recovery

RT: Total heat recovery.

TE: Electronic thermostatic valve

RV: Personalised RAL paint (model RWE monocircuit)

SN: Main switch (model RWE monocircuit)

V: Voltmeter.

VB: Brine version (water temperature  $< 0^{\circ}\text{C}$ )

## 4. INSTALLATION

### 4.1 Identification tag

The data for the identification of the unit are marked on a permanent tag (Picture 10).

<b>EMICON</b> AIR CONDITIONING AND INDUSTRIAL APPLICATION		TEL. ++39 0845 418815 FAX ++39 0845 418812 Via Ortopoli 89-Pal. F.I.C.I., 1		<b>CE</b>
MODEL MODELLI MODEL		MODEL MODELLI MODEL		
NB 0407	SERIAL NO. NUMERO IN SERIALE SERIAL NUMBER		NUMBER OF SERIAL NUMERO IN SERIALE	
DRYING TENDENZA TENDENZA	Y-PH-Hz	VOLTAGE VOLTAGGIO		
REFRIGERANT TIPO DEL REFRIGERANTE TYPE OF REFRIGERANT	R	REFRIGERANT REFRIGERANTE		
REFRIGERANT QUANTITÀ MISURATA NEL CARICO	Kg	REFRIGERANT QUANTITÀ MISURATA NEL CARICO		
REFRIGERANT MISURATO NEL CARICO	Kg	REFRIGERANT MISURATO NEL CARICO		
MAX. PRESS. (BAR) MAX. PRESS. (BAR) MAX. ALLOWABLE PRESSURE	L.P. bar	H.P. bar	MAX. PRESS. (BAR) MAX. ALLOWABLE PRESSURE	
ADDRESS CONTRIBUTION INDICARE IL CONTRIBUTO DELL'INSTALLAZIONE			ADDRESS CONTRIBUTION INDICARE IL CONTRIBUTO DELL'INSTALLAZIONE	

Picture 10 - Identification tag



The correct unit identification by means of the serial number is essential for the execution of any operation to carry out on the unit. The serial number must be always advised whenever submitting a request of technical service support.

### 4.2 Reception and inspection

It is very important to check the packing integrity immediately upon delivery. In case the packing is found damaged, it is necessary to accept the goods "with reservation" and indicate on the consignment note the state of the received goods and let the driver countersign it. Any claim concerning the delivered material must be sent to the manufacturer by fax or by registered letter within 8 days from the receiving date. It is advisable to unpack the unit only when the installation begins and possibly after the unit has been moved to the location where it must be installed.



It is forbidden to stack units, even if they are packed. If the unit is stored after receiving, it must be not exposed to weather agents, even if packed.

### 4.3 Handling

The handling of the unit must be carried out by expert personnel, equipped with appropriate equipment in relation to the weight and to the dimensions of the machine. During the handling operation, the machine must be always kept upright.



The weight of some models is unbalanced: check the unit stability before starting to handle it.

For any unit handling, please follow the instructions shown in Pictures 11, 12 and 13. In case the fork lift is employed, the forks must be spaced out to the maximum allowed by the pallet size. In case the machine is moved by means of a crane, it is important to avoid that cables and belts exert a too high tractive effort on the packing that might damage it.



Angle  $\alpha$  must not be greater than  $30^\circ$ ; the pictures are just as an indication.



*SCHEMA DI SOLLEVAMENTO*

*SCHEMA DE LEVAGE*

*LIFTING DIAGRAM*

*HEBESCHEMA*

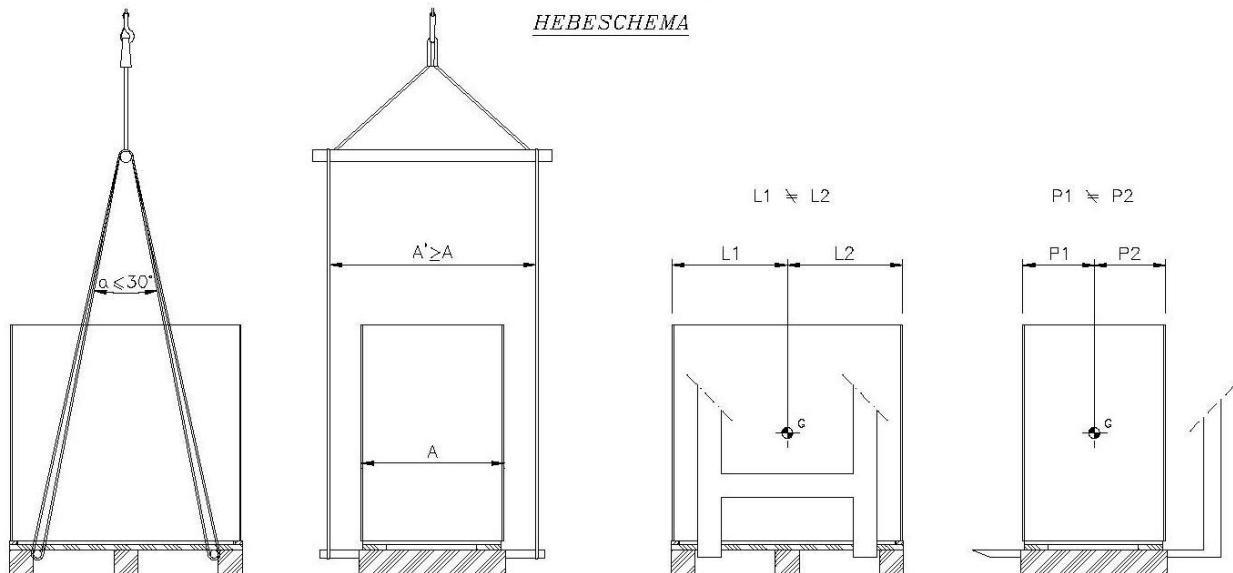

Pict. 11 - Lifting of monocircuit units





SCHEMA DI SOLLEVAMENTO

SCHEMA DE LEVAGE

LIFTING DIAGRAM

HEBESHEMA

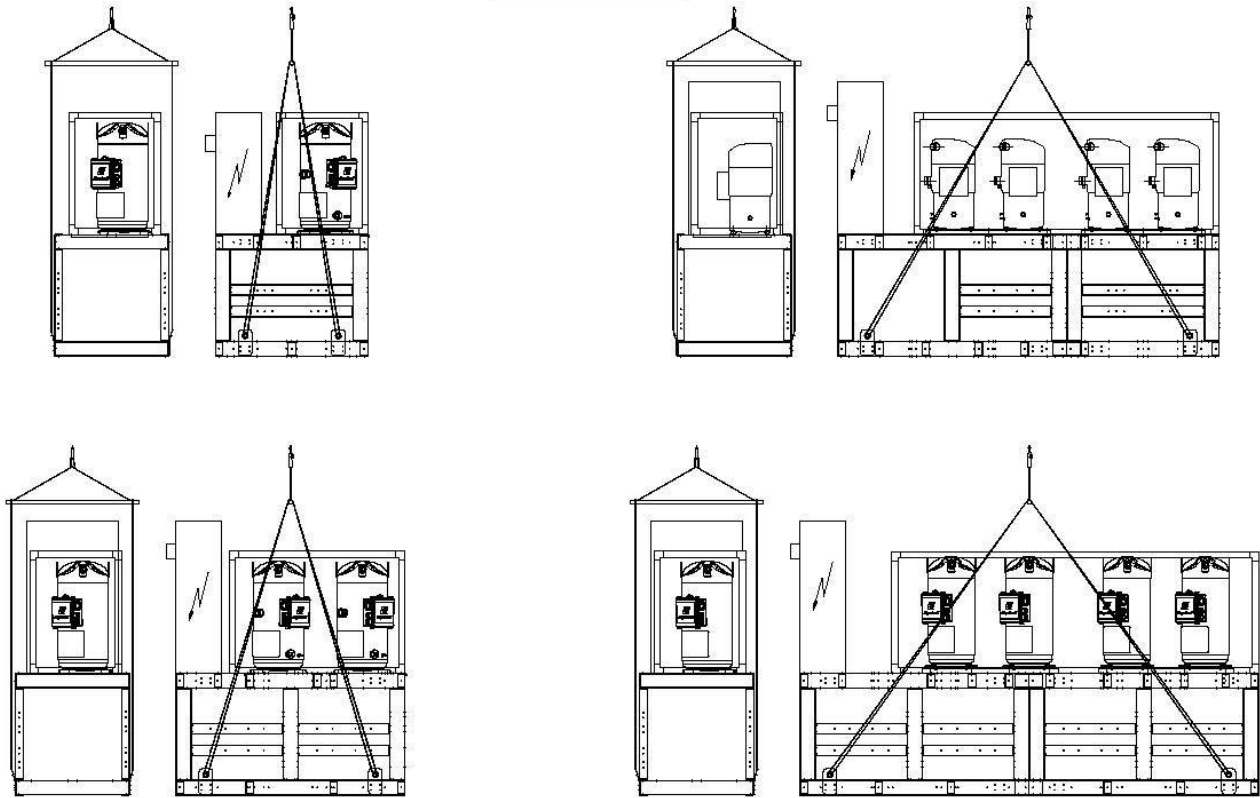

Pict. 12 - Lifting of scroll multicompressor units



*SCHEMA DI SOLLEVAMENTO*

*SCHEMA DE LEVAGE*

*LIFTING DIAGRAM*

*HEBESCHEMA*

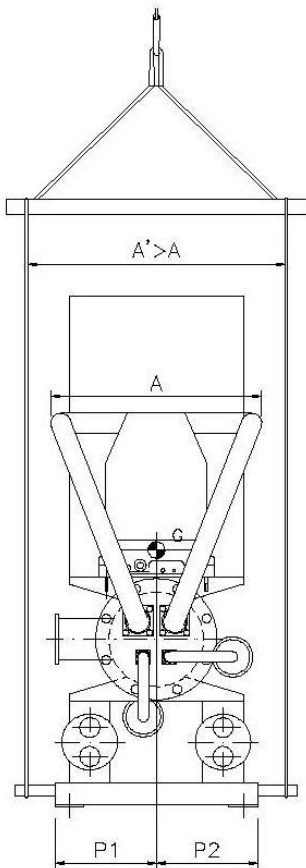

$P1 \approx P2$

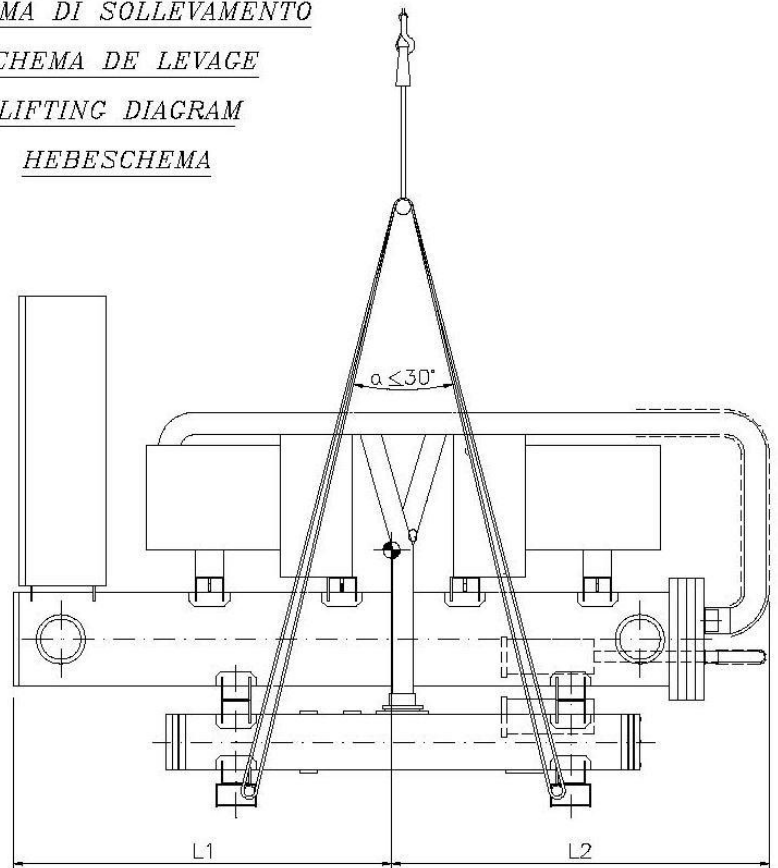

$L1 \approx L2$

Pict. 13 - Lifting of screw multicompressor units



In case the manufacturer lifting kit (option) is not employed, make sure that the lifting equipment used, the cables and the belts are in compliance with the relevant local regulation.

The overall dimensions of the units, packaging included, are indicated in the packing list sent by e-mail in order to organise the loading.

#### 4.4 Arrangements and placing

The installation of the machine is under the responsibility of the installer who must supervise the execution operations.

The execution of a correct installation presupposes that a plan has been drawn up by an expert and that is carried out by skilled and trained technicians. In the following paragraphs there are some tips and information to keep in mind when planning and executing the machine installation.



The unit installation must comply with local existing laws.

Before placing the unit, the following points must be checked:

- Ø Connections for electric and hydraulic circuits must be done;
- Ø Enough room must be left around the unit to allow the routine and the special maintenance, such as compressors and heat exchangers replacement. The dimensions of this free space is represented by the dashed area as shown in Pictures 14, 15 and 16, for units with single and multi-scroll compressors and for units with screw compressors.
- Ø The floor where the machine is positioned can bear the total unit weight under normal operation.

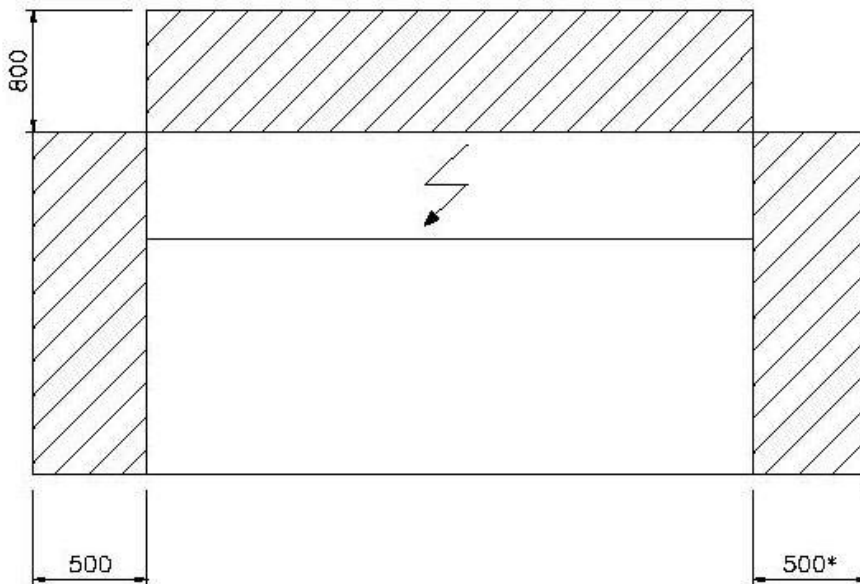

- \* E' NECESSARIO RISPETTARE QUESTA DISTANZA ANCHE PER IL COLLEGAMENTO IDRAULICO DEI MODELLI CON OPTIONAL RP.
- \* IL EST NECESSAIRE DE RESPECTER MEME CETTE DISTANCE POUR LA CONNECTION HIDRAULIQUE POUR LES MODELES AVEC LES OPTIONS RP.
- \* IT IS NECESSARY TO SAFE THIS DISTANCE TOO, FOR THE HYDRAULIC CONNECTION USING THE MODELS WITH OPTIONAL RP.
- \* BEI MODELLEN MIT OPTION RP MÜSSEN FÜR DEN HIDRAULIK ANSCHLUSS AUCH DIESE ABSTANDE EINGEHALTEN WERDEN.

Pict. 14 - Service Area for monocircuit units

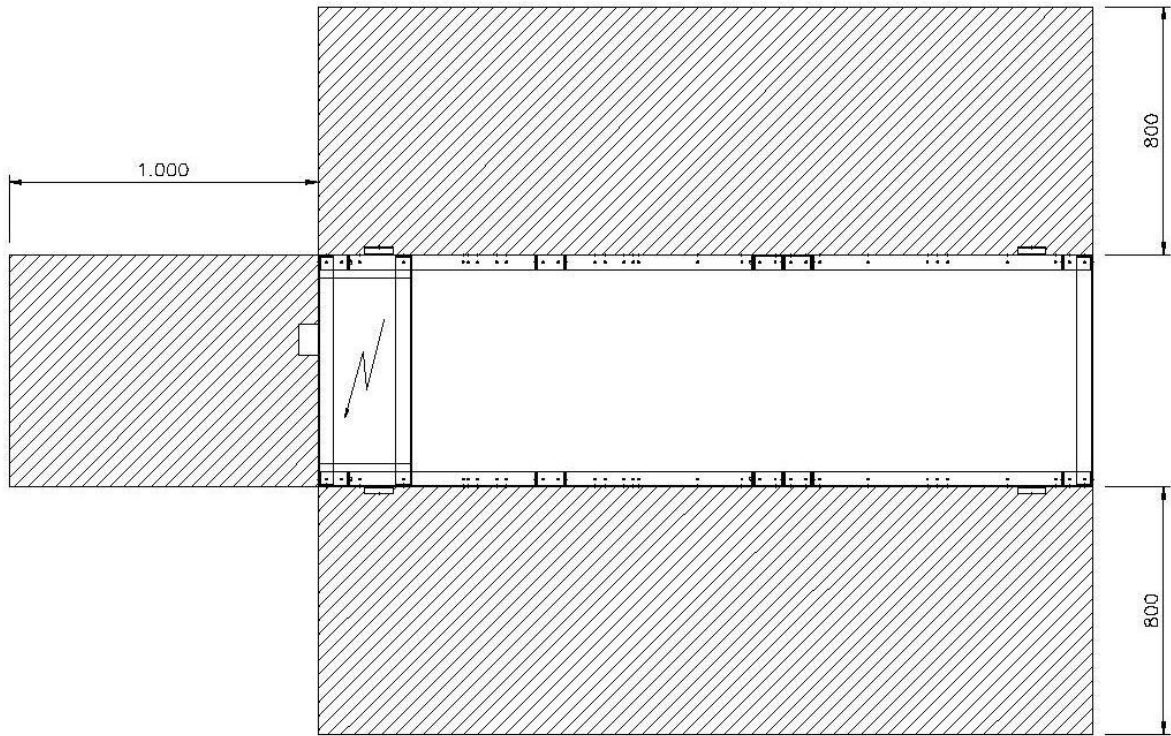

Pict. 15 - Service Area for multicompressor scroll units

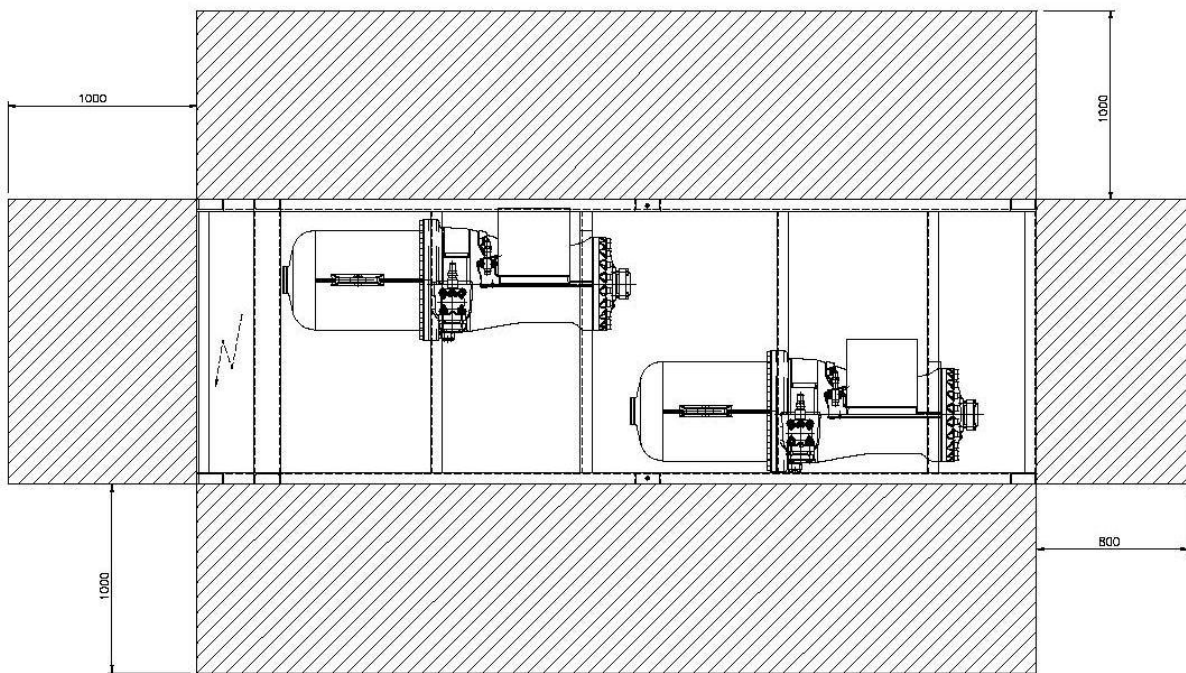

Pict. 16 - Service Area for multicompressor screw units

Before starting to handle the unit to position it, it is necessary to identify the best way to arrive to the place, taking into consideration the unit overall dimensions and weight, the available lifting equipment and any optional accessory dimensions. All units described in this manual do not need any special foundation, since they can be simply laid down on the chosen surface, just placing rubber gaskets or spring-type vibration dampers (options) underneath. Make sure that the unit features indicated in the attached technical data sheets match those required for the undertaken project.

#### 4.5 Cooling connections

These units are supplied with nitrogen charge (20 bar). Discharge pressure carefully only before carrying out the cooling connections.

Since the machines are conceived to work with air cooling system, copper pipes must be employed for the connections to their ventilated condenser units which are installed outdoor.



Even if refrigerant is not classified as a toxic substance, pay the maximum attention during the refrigerant charge operation and strictly follow the security requirements in compliance with law by decree 81/08 ; in particular, the appropriate and necessary equipment must be worn to avoid contact, inhalation and ingestion.

If any of the above mentioned cases occurs, it is advisable to consult the security specifications for the operations of first aid and emergencies concerning the employed refrigerant.

In case it is necessary to go to the doctor, it is advisable to bring these refrigerant security specifications with you

The pipe installation must be performed by a skilled refrigeration technician.

The piping path must be as shortest as possible in order to reduce the quantity of refrigerant gas and oil circulating and to reduce the pressure drop. If copper pipes have to cross electric wires, it is advisable to isolate the tubes in order to avoid the danger of inducted current. Lines must be realised with copper tubes, specifically conceived for cooling systems and they must have an appropriate diameter, as shown in attached drawing .

It is here reminded that the total piping length is the result of its geometrical calculation plus the length of valves, bents and fittings present on the line itself. If failing to have more accurate information, you can obtain the total length by multiplying the geometrical length of the line by 1,5 or 2.

Copper pipes must be adequately supported by brackets so as to make them secure and fasten, and at the same time allow thermal expansion of the copper tubes.

If the discharge pipes go through rooms where people normally live, it is advisable to install rubber vibration dampers and a sound attenuator as nearest as possible to the compressor.

The piping insulation, except for special requirements, can be applied on the following parts only:

- Ø Suction pipes;
- Ø Discharge pipes, where pipes are lapped by the unit air discharge (in the suspended floor); where pipes can be accessible to unauthorized people so that any damage or skin burn can be avoided.

During the piping installation, the refrigerant tubes must be sealed to prevent humidity and dirt go inside. The piping arrangement must consider easy access for operations like bracket insertion, tube welding and inspection.

Once pipes are placed, before carrying out the connections to the unit, the system must be leak tested by means of pressurized nitrogen. It is recommended to mark the pressure test value on a pressure gauge.



Do not exceed 20 bar when pressing with nitrogen.

The nitrogen also enables the circuit to dry up. If the circuit pressure drops, this means that the circuit is not sealed off. It is, then, necessary to let in a small quantity of refrigerant so that it is possible to locate any leak by means of appropriate detectors. If a leak is detected, after the repair, a new leak test must be carried out again.

Finally, the vacuum and the charge of the system can be executed following the instructions as described in par. 4.6

## 4.6 Vacuum and charge execution of the system

### 4.6.1 General warnings

For a correct and reliable operation of the system, once the connection lines between the indoor and the outdoor units are carried out, it is extremely important to clear the circuit of any air, humidity, non-condensable gas and, in general, of any polluting substance presence before executing the refrigerant charge. The presence of solid particles like metal dust, welding debris and dirt of small dimensions that cannot be detected by the mechanical filters can cause serious damages to the surfaces in movement and involve a reduction in efficiency and of compressor life.



Do not perform any holes in the cooling circuit, the complete rescue of metal particles produced would be then prevented.

If excessive humidity persists inside the cooling circuit, negative consequences can arise. Humidity can freeze inside the thermostatic valve and can even clog it up, causing the unit stop because of the low-pressure alarm. A significant amount of humidity can saturate the filter drier in a very short time and it will be necessary to replace it (with consequent operating interruption of the system). Humidity chemically interacts with the refrigerants and especially with polyester lubricant oils (normally employed with refrigerant type R407C, R134a, R404A, etc.). This interaction creates acid substances that, if present in fair amount, can damage the compressor electric motor insulation provoking motor burns and rusted copper pipes that can generate solid impurity.



Reduce as least as possible the exposure of the circuit and its part to the atmosphere, especially if compressors are charged with polyester oil.

If non-condensable gases are not eliminated accurately from the circuit, they can gather inside the condenser and the liquid receiver. If gases are in the condenser, they can cause a reduction of the useful thermal exchange surface, meaning a condensing temperature increase and, consequently, a reduction of the energy efficiency and of the system reliability. In worst cases, the unit can be stopped by the activation of the high-pressure switch. Big amounts of non-condensable gases gathered in the liquid receiver can cause the malfunctioning of the thermostatic valve, in case a mixture of refrigerant and non-condensable vapor replaces liquid refrigerant. If this happen, there will be a strong reduction of the evaporating temperature up to the activation of the low-pressure switch, in worst cases, thus involving a reduction of the unit cooling capacity and a reduction of the system efficiency and life.

Picture 14



Picture 15



### 4.6.2 Vacuum execution

Once the cooling lines are completed and checked that no leaks are present, the vacuum must be executed as described here below (see Par. 4.5).



The indoor unit is normally leak tested by the manufacturer by cooling circuit pressurization.



The unit is supplied with nitrogen pressure (20 bar). Therefore, if during the installation it results that the cooling circuit is not pressurized, this means that there is a leak. It is necessary to detect it and repair it before going on with the installation operations.



Before starting the circuit vacuum operation, make sure all nitrogen contained in the liquid receiver has been discharged.

a) Connect a vacuum pump (a two-stage pump able to keep a pressure of 0,04 mbar - Picture 14) to the system employing the charge connections present on suction (Picture 15) and on liquid lines. The vacuum pump must have a suitable water flow capacity for the circuit size.



Do not use the compressor for carrying out the vacuum inside the cooling circuit.



Make sure all valves are open in order to avoid that some circuit parts result cut off.

b) Let the vacuum pump work until the pressure shown on the appropriate vacuum meter (Picture 14) does not go below 10 mbar.

c) Isolate the pump from the circuit by means of the appropriate cut-off valves and wait for 30 min.

d) If pressure goes on increasing during the pump stop period or if it is impossible to reach the desired pressure value, it means there is a leak in the circuit. It is necessary to detect and repair the leak, and after that, a new procedure must be performed again starting from step b).

e) If pressure goes up until it reaches a climax value, it means the circuit contains a big amount of humidity. In this case, it is necessary to let in nitrogen in the circuit (up to about 2 bar) and then repeat steps b), c) and e) for at least twice, then proceed with step f).

f) If pressure stabilizes after a short increase, it means the circuit is leak proof and reasonably dried. Start up again the pump after the shut-off valves are open and let it operate for 2-4 hours according to the circuit size after pressure has returned below 10 mbar.



Do not operate the compressor nor empty a megahom meter while the circuit is vacuum.

#### 4.6.3 Refrigerant charge execution

Once vacuum is completed, the circuit must be charged with the exact quantity of refrigerant and, if necessary, of anti-freeze oil.



Avoid any refrigerant gas release in the environment during the charge operations.



a) Connect a full up refrigerant gas cylinder to the circuit employing the charge connections present on the liquid line.

Make sure the refrigerant you are going to use for the circuit charge is the same as shown in the unit identification tag. In case of discrepancies, contact the manufacturer.



b) Open the cylinder valve and charge the refrigerant until the circuit pressure reaches the same pressure as in the cylinder (if needed, repeat the operation with additional gas cylinders).

If the refrigerant is a mixture compounds, make sure to let enter the circuit in a liquid state in order to avoid compounds separation. On this purpose, cylinders are provided with two distinct valves: one for the vapor and one for the liquid.



c) Shut off the cylinder valve, disconnect it from the liquid line and connect it to the suction line (possibly prior to the evaporator).

d) Start up the unit, open the cylinder liquid valve and complete the charge (if needed, use more cylinders) until the sight glass located immediately after the filter drier becomes clear and does not present foam or gas bubbles during the operation in nominal conditions.

In order to facilitate the charge operation, the following tables show, as an indication, the necessary amount of refrigerant to charge the different types of indoor units and the corresponding connecting pipes. For a correct calculation of the refrigerant quantity, it must be also taken into account the volume of the outdoor unit cooling circuit and of any other component installed (such as additional liquid receivers, oil separators, etc.). In case the cooling lines are very long or in case oil separators are installed on the compressors discharge, a fair quantity of anti-freeze oil must be added.



Check if the employed oil is compatible with the one charged in the compressor (check it out in the compressor's identification tag).

In case oil separators are employed, add the lubricant quantity suggested by the manufacturer.

If cooling lines are longer than 30 m, charge about 0,2 kg of oil every 10 m of piping (beyond 30 m). In any case, check the correct oil charge by checking the oil level through the compressor sight glass after about 30 minutes of standard operation mode.



An overload oil charge can lead to a system efficiency drop and to compressor breaking.

## 4.7 Hydraulic connections

The units are designed to be connected to a distribution system of cooled water. Only expert refrigeration technicians are allowed to perform the hydraulic connections and in conformity with local regulations. The following general instructions must be followed

- Ø Perform the piping path in such a way so as to limit as much as possible the pressure drop in the system.
- Ø The water circulating pump must be able to deliver the appropriate water flow capacity with the necessary available pressure to overcome the system pressure drop in any operating conditions.
- Ø Pipes must be adequately supported by brackets and arranged so as to allow an easy installation and inspection.
- Ø The materials used for the realisation of the system must have a nominal pressure not lower than PN6.
- Ø During the piping installation, all necessary measures to prevent dirt and solid particles from entering the tubes must be taken.
- Ø Once the pipes are placed and the unit installed, the system must be leak tested to detect any possible leak to be repaired before the starting up of the system



Do not exceed 6 bar during the leak test!

- Ø The unit must be connected to the hydraulic system by using the appropriate areas as indicated in the commercial drawing here attached.
- Ø The diameter of the hydraulic connections are shown in the commercial drawing here attached.



#### 4.7.1 Evaporator

For the connection of pipes to the evaporator, it is advisable to follow the instructions listed here below:

- Ø Connect the pipes as shown in the diagram in Picture 19;
- Ø Employ anti-vibration pipe fittings to avoid any vibration transmission and to allow the thermal expansion;
- Ø Install on the water inlet a filter with grid not larger than 1 mm and with a bigger diameter than the pipe diameter;
- Ø Place the air discharge valves in the appropriate points of the hydraulic system;
- Ø Install a ball check valve on the inlet and outlet so that it is possible to shut off the unit in case of special maintenance operations. The installation of three-piece joints between the valves and the chiller will ease these operations;
- Ø The water system pressure must range between 1,5 and 3,5 bar.
- Ø In case of low evaporating temperatures ( $< 4^{\circ}\text{C}$ ) it is recommended to employ anti-freeze mixtures (glycol) as shown in the following tables, according to the kind of glycol used:

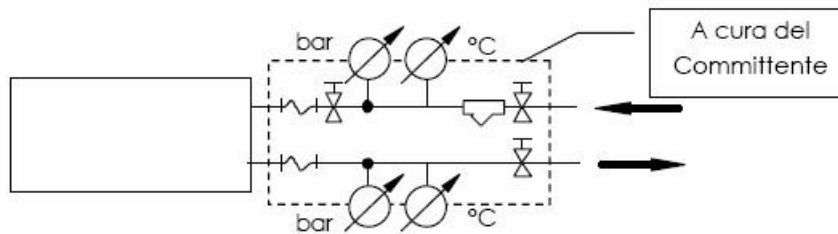

Pict. 19 - Piping connection diagram



If the unit is not equipped with a differential pressure switch (option), it is advisable to install a flow switch on the hydraulic circuit stopping the unit in case of insufficient exchanger water flow. Such a device shall be connected to the foreseen terminals inside the electrical board (see attached wiring diagram).

If the anti-freeze mixture contains a lower ethylene glycol percentage than below recommended, there could be risks of freezing, while a higher percentage can reduce the unit performance. At the beginning of every winter, it is recommended to check the correct concentration of glycol in the system.



Do not use anti-freeze liquids unsuited to copper, stainless steel and to all other materials present in the system.



The cooled water system must be heat insulated with closed-cells material having adequate features of heat insulation and steam resistance for the unit operating conditions.

Descrizione	Percentuale di glicole etilenico sul peso della miscela							
	5%	10%	15%	20%	25%	30%	35%	40%
Temperatura di congelamento	-2,1	-4,5	-7	-10	-13	-17	-21	-25

#### 4.7.2 Use of anti-freeze mixtures

In case an anti-freeze mixture is used, it is necessary to follow some precautionary measures:

- Ø The temperatures shown in the above table are approximate. Sometimes suppliers dilute the product and therefore it is necessary to follow the dilution percentage recommended by the anti-freeze liquid manufacturer.
- Ø Do not release the anti-freeze solution in the environment, but deliver it to an authorized waste disposal facility.
- Ø Make sure the anti-freeze fluid used is compatible with the system materials.
- Ø If we increase the anti-freeze quantity we get a higher anti-freeze protection, but as a consequence the solution will become denser (and more viscose when cold), thus overloading uselessly the circulating pump and thus reducing the unit performance.
- Ø Do not use anti-freeze substances such as chloride or other products that might cause electrogalvanic corrosion.
- Ø Change the anti-freeze solution every two years.



The inhibited monoethylene glycol is harmful if ingested and can cause irritation if on contact with skin and sensitive mucous membranes. Therefore, it is recommended to wear protection glasses and gauntlets and to avoid the contact with the mouth; follow the safety instructions indicated on the container or in the corresponding directions.

#### 4.7.3 Hydraulic circuit filling

Once the hydraulic circuit and the unit connection are performed, it is necessary to fill the circuit.

- Ø Open all the air discharge valves on the circuit.
- Ø Connect the circuit to a water supply system, possibly in a permanent way, by means of an automatic fill group provided with a manometer and a non-return valve.



If the circuit works with an anti-freeze mixture, fill the circuit with an appropriate quantity of pure anti-freeze fluid according to the system size and to the anti-freeze concentration to get.

- Ø Start filling the system with water;
- Ø Check all the air discharge valves present on the system and shut them when water, instead of air, starts to go out.
- Ø Once all valves are closed, go on filling the system with water until a pressure between 1,5 and 3,5 bar is reached..

In case filling is done manually, stop the water charge and start the circulating pumps so that any presence of air can be gathered in the top points where air discharge valves are present. After two operating hours, stop the pumps and discharge the air by means of the air discharge valves. Charge more water to bring pressure back to its original value. Repeat the operation until no air goes out from the air discharge valves.



Make sure the water pressure in the system always ranges between 1,5 and 3,5 bar.



After the leak test with water is performed, if low ambient temperatures or a long break before the startup are likely, it is recommended to drain the circuit or to fill it with an anti-freeze mixture. The draining must be particularly accurate in case free-cooling coils are installed.

## 4.8 Electric connections

Check the electric circuits have not been damaged during transportation. Check all terminals screws are tight. Make sure the power tension and frequency match the same data as specified on the unit identification tag



Before starting the electric connection, it is advisable to check the wiring diagram contained in the unit electric panel.

### 4.8.1 Electric connections to the remote condenser

The condensers and the remote condensing units must be connected to the appropriate wire terminals in the indoor unit by means of an electric cable having an adequate diameter and suitable features related to the capacity and the environment

### 4.8.2 Power supply connection

The unit can be powered with a 5-pole cable (3 poles+N+ T), if the power supply tension is 400V/3F/50Hz. In case the power supply tension is 230V/3F/50Hz, the supply cable is a 3-pole cable. On demand, it is possible to supply units with arrangements for special power supply tension (check the identification tag and the wiring diagram).

Connect the phases and the neutral to the terminals of the main switch and the earth wire to its corresponding terminal. Use a power supply cable of adequate cross section and of moderate length to avoid voltage drops. Protect the power supply cable by means of an automatic switch of appropriate size and features.



For the cross section of the power supply cable, the size of the automatic switch and the characteristics of the electric components, check the wiring diagram attached to the present manual.

### 4.8.3 Warning in case of connection to the terminal board when optional "TE" is installed

In case the unit is provided with optional TE (electronic thermostatic valve), pay the maximum attention to the spare battery power supply.

"GB1" (spare battery) is an electronic device which guarantees a temporary power supply to the "Driver" device in case of sudden power supply shortage, thus allowing the immediate shutoff of the thermostatic valve.

Before performing any operation, it is advisable to check the charge of the battery as per the instructions;

- Ø Power the control
- Ø Press the button I/O
- Ø Check parameter N4

For further information, check the control manual on chapter 7, section "input-output/driver" and chapter 9. If battery is flat, 48 hours are needed to charge it.

During the check-up operation before the unit startup, it is advisable to disconnect the spare battery to avoid that continuous power and disconnection operations might damage it.

- open the duct above the component GB1 (driver battery EVV) and disconnect the power supply cables (see the picture)



**Pict. - 19**



**Once the test is completed, it is reminded to re-connect the battery to bring the unit back to a safety condition**

#### 4.8.4 User's terminal board connection

A user terminal board (Pict. 21) is available with free contacts designed for:

- Ø Generic alarm state (1);
- Ø Unit remote ON/OFF (2).

Check the wiring diagram for the exact correspondence of the terminals numbers.

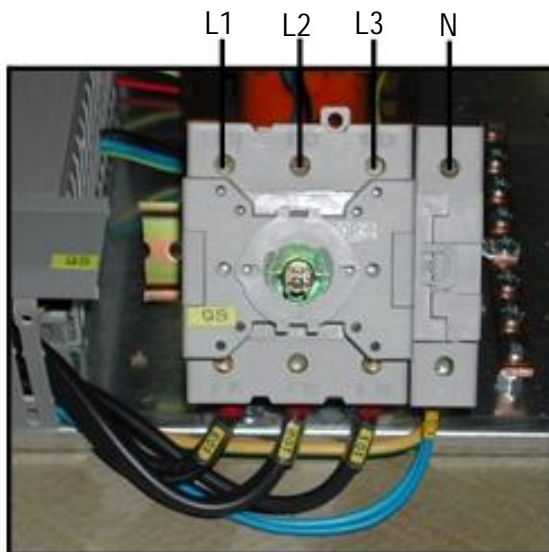

Pict. 20



Pict. 21

#### 4.8.5 Instructions for the electric connection

The electric connection must be carried out by skilled personnel. The power cable input is shown in the attached dimensional scheme.

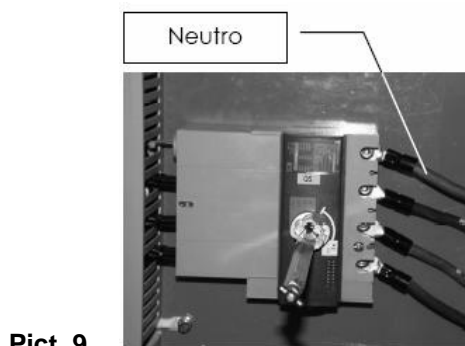

Pict. 9

The power cable conductors must be connected to the free terminals upstream the main disconnecting switch, while the grounding conductor must be connected to the appropriate terminal PE or to the ground bar. On the lateral side of the unit, a hole must be performed to introduce the electric power cable and to arrange its corresponding cable connection.

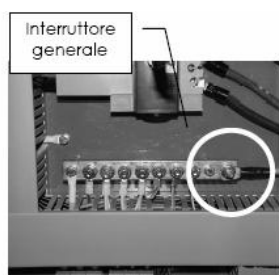

Pict. 10

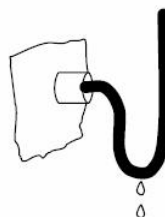

Pict. 11



If the power cable comes from the top wiring box, perform a bend on the cable (Picture 11) before plugging it into the cable connection as illustrated in the example on the top on the right.

If the water circulating pump is not controlled by the unit microprocessor, it is recommended to connect an auxiliary contact of the pump electromagnetic switch to the remote ON/OFF terminals preset in the electrical panel (see attached wiring diagram), so that the unit can start only when the pump is working.

On its cover, the electrical board has the programming panel of the unit microprocessor. For the controls management, its functions and for the microprocessor use, see Chapter 8 "Unit control and start-up" of the present manual.

Pict. 12

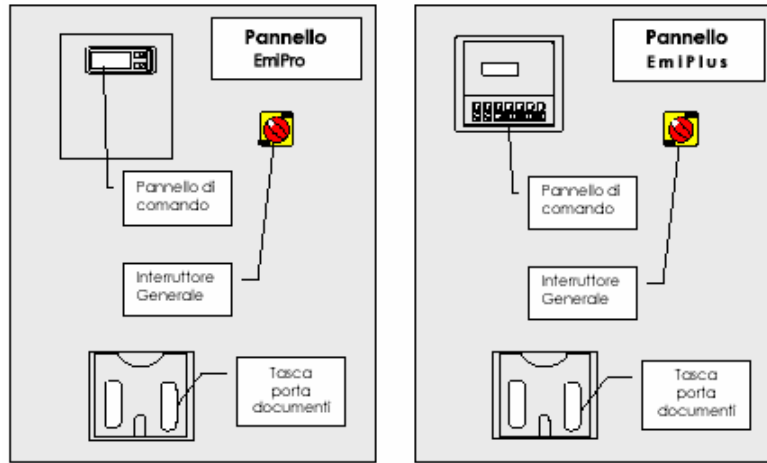

#### 4.8.6 Phases sequence in the power supply line

The rotation direction of all electric motors installed on the unit (compressors, fans, pumps) are checked and harmonized during the operational test performed by the manufacturer (at the exception of units supplied with arrangements for special power supply tension). In case of three-phase power supply, when connecting the unit to the power supply, it is necessary to check that the phases are connected in the correct sequence. On this purpose, make sure that all electric motors rotation is right: for pumps and fans, refer to the information indicated on the component itself; for scroll compressors, follow the instructions as described at Par. 5.1.

If the rotation of any component is wrong, two out of three phases must be inverted in the terminals of the main switch (do not unplug the neutral). If some components go on rotating in the wrong direction, check the conductors sequence of each 3-phase component and correct it, if needed.

#### 4.8.7 Applications

The nominal water flow capacity refers to a temperature difference of 5°C between the inlet and outlet depending on the supplied cooling capacity. The maximum allowed capacity is equal to 1,2 times the above mentioned value (higher flow rates could cause noise and vibrations with consequent damage to the evaporator).

The minimum allowed flow capacity is equal to 0,8 times the nominal value (lower flow rates might cause a too low outlet water temperature thus involving the safety device activation and the unit stop).

## 5. OPERATION

### 5.1 First check

Prima di avviare la macchina assicurarsi che:

- Ø The evaporator water side is supplied with a suitable water flow according to the project;
- Ø The hydraulic connections are carried out following the use and maintenance manual;
- Ø The hydraulic circuit is charged and air free;
- Ø The shut-off valves on the hydraulic circuit are open;
- Ø All security conditions are respected;
- Ø The unit is placed correctly on the floor;
- Ø The service area is respected;
- Ø The electric connections are performed correctly;
- Ø The electric tension ranges within a tolerance of 10% compared to the unit nominal tension;
- Ø The connection to ground is performed correctly;
- Ø All electric and hydraulic connections are tight properly.

If a 3-phase scroll compressor is installed on the unit, when starting, check the rotation is correct. If the compressor rotates in the opposite direction, it produces a higher noise level, it causes a pressure difference between discharge and suction and its electric absorption is lower than scheduled; after few minutes of operation with the reversed rotation, the internal heat protection can be enabled. If necessary, reset the correct rotation direction by inverting two out of three phases in the input terminals of the main switch.

### 5.2 First startup

The first startup must be performed by a skilled refrigeration technician. The oil heaters must be energized for at least 3 hours before the unit startup, and for 6 hours in case of screw compressors. Check the shut-off valves on compressor and on the cooling circuit are open. Make sure all points described in the previous paragraph have been checked.

To start the unit:

- Ø Turn the main switch to "ON" position.
- Ø Press the ON/OFF button on the microprocessor keyboard.



Compressors startup time-delay has a default value equal to 1 minute and it can be re-set. Check all safety and control devices are working properly.

To stop the unit:

- Ø Press the ON/OFF button on the microprocessor keyboard;
- Ø If the unit must not work for more than 24 hours, turn the main switch to OFF position.

### 5.3 Microprocessor setting

Make sure the desired parameters are set on the microprocessor.

If the preset parameters need to be changed, proceed as described in the microprocessor manual (here attached).



The standard units are designed to work with an outlet cooled water temperature higher than 5°C; for operation at lower temperatures, use anti-freezing solutions having adequate properties. If necessary, set the anti-freeze set point.



## 5.4 Fault alarm and display system

The troubleshooting is realized by the microprocessor, which activates an alarm and shows on its display the type of fault occurred (see also the attached microprocessor manual). Since the alarm state is very often generated by an unfitted electric contact, in case of fault make sure all wiring connections are plugged in the corresponding terminals. In case of fault, consult the attached microprocessor manual to check the parameters setting has been done properly

## 5.5 Troubleshooting

TROUBLE	POSSIBLE CAUSE	CORRECTIVE ACTION
1. The unit does not work	A) The electric panel is not powered.	Check presence of electric tension; make sure the main switch is closed.
	B) The auxiliary circuit is not powered.	Check fuses FUT and FUA
	C) The microprocessor does not start the unit	Check the electric connections to the microprocessor and the setpoint
	D) The external impulse to the microprocessor fails	Check the remote ON/OFF contact is closed
2. Cooled water temperature too high	A) The unit does not work	See trouble 1
	B) The control system setting is not correct	Check the setting of the control system
	C) The compressor does not work	See trouble 11
	D) The compressor output is not sufficient	See troubles 7 and 10
	E) The control system does not work	Check the attached Microprocessor manual
	F) Thermal load higher than estimated	Check the thermal load value
3. Cooled water temperature too low	A) The control system setting is not correct	Check the setting of the control system
	B) The control system does not work	Check the attached Microprocessor manual
	C) The cooled water flow capacity is too low	See trouble 4
4. Cooled water/condensing water flow too low	A) The water pump does not work	Check the pump electric connections
	B) Pressure drop in the hydraulic system higher than estimated	Check the pressure drop and compare it with the pump head pressure
	C) The pump heat protection is activated	Check pump winding electric resistance; after reset, check tension and electric absorption
	D) Obstruction in the hydraulic circuit	Make sure filters are not clogged; check the shut-off valves on the circuit are open.
	E) Air presence in the hydraulic circuit	Discharge the air by means of the air discharge valves on the hydraulic circuit

TROUBLE	POSSIBLE CAUSE	CORRECTIVE ACTION
5. The high pressure switch is activated	A) The high pressure switch is not set properly or is defective	Replace the high pressure switch or reset it
	B) Discharge pressure too high	See trouble 7
	C) The condensing water flow capacity is not sufficient	See trouble 4
6. The low pressure switch is activated	A) The low pressure switch is not set properly	Replace the low pressure switch or reset it
	B) The cooled water flow capacity is not sufficient	See trouble 4
	C) Suction pressure too low	See trouble 10
7. High compressor discharge pressure	A) Suction pressure too high	See trouble 9
	B) The finned heat exchanger is dirty	Remove the obstructing material (leaves, paper, seeds, etc.)
	C) Circuit charged with too much refrigerant	High refrigerant undercooling: discharge some refrigerant from the circuit
	D) Non-condensable air or gas in the circuit	The flow sight glass shows gas bubbles. The compressor discharge temperature is high; the cooling circuit must be discharged and recharged after the vacuum execution.
	E) Too hot water at the condenser	Check capacity of the condensation water cooling system
	F) Condensing water flow capacity insufficient	See trouble 4
	G) Encrusted condenser	Wash the exchanger with suitable products
8. Low compressor discharge pressure	A) The control system of the condensation pressure is not working properly	Check setting and operation of the thermostatic valve
	B) Suction pressure too low	See trouble 10
9. High compressor suction pressure	A) Thermal load higher than estimated	Check the room thermal load value
	B) Discharge pressure too high	See trouble 7
	C) Liquid refrigerant return to the compressor suction side	Make sure the thermostatic valve overheating is correct; check the valve bulb is properly placed, fixed and insulated.
10. Low compressor suction pressure	A) Cooled water temperature too low	See trouble 3
	B) Cooled water flow capacity too low	See trouble 4
	C) Clogged refrigerant filter	Check the refrigerant filter
	D) The thermostatic valve is not set properly or is defective	Check the thermostatic valve overheating is correct; check the thermostatic element is not damaged
	E) Refrigerant charge is insufficient	Check possible leakage and recharge
	F) Discharge pressure too low	See trouble 8

TROUBLE	POSSIBLE CAUSE	CORRECTIVE ACTION
11. The compressor does not work	A) Automatic switch activated	Reset the automatic switch; check the cause for the activation
	B) Compressor internal heat protection activated	Check the compressor winding resistance; after reset, check the tension and the electric absorption; check the working parameters are in the nominal range of values.
	C) The contactor does not work	Check the contacts and the contactor coil
12. The compressor is noisy	A) Liquid return to the compressor	Check the thermostatic valve overheating is correct; check the valve bulb is properly placed, fixed and insulated.
	B) The compressor is damaged	Replace the compressor
13. Probe alarm	A) The probe corresponding to the alarm code is defective or disconnected	Check the probe connection and if it works; in case of defect, replace it.

## 5.6 Routine maintenance

### 5.6.1 Type and frequency of periodical checks



Before accessing any component inside the unit, turn the main switch of the power supply to OFF position. Then, also turn the unit main switch to OFF position.



Only trained technicians are allowed to perform operations with powered electrical panel and with open panel board, since some functions of the system fail.

It is recommended to carry out periodical checks in order to make sure the unit works properly. Only authorized and skilled technicians are allowed to perform this kind of operations, included any maintenance operation.

### 5.6.2 Operations on the cooling circuit

Every time an operation involves the cooling circuit discharge, the gas must be collected by means of the appropriate gas recovery for environmental safety reasons.

Once the repair on the cooling circuit is performed, carry out the following operations:

- Ø Leak detection;
- Ø Vacuum and dehydration;
- Ø Refrigerant charge

#### A) LEAK DETECTION

Charge the cooling circuit with the gaseous refrigerant up to reach a pressure of 1 bar. Then, add anhydrous nitrogen by means of cylinders with reducer up to reach a pressure of 15 bar.

Look for possible leakage and, if present, discharge the cooling circuit before welding (with phosphorus copper alloy with a minimum of 2% of silver).



Discharge completely the cooling circuit before welding in order to avoid explosions.



Do not use oxygen instead of nitrogen in order to avoid explosions.

## B) VACUUM AND DEHYDRATATION

To obtain a good level of vacuum, an appropriate pump must be used (1,4 mbar of absolute pressure, 30 l/min. of water capacity). If the circuit has been open only for short time, by using this pump, only one vacuum operation is usually enough to reach the absolute pressure 1,4 mbar. If such a vacuum pump is not available or if the circuit has been open for long time, it is highly recommended to perform the vacuum three times by breaking the vacuum by means of the refrigerant. This method is also suitable when there is a high quantity of moisture in the circuit. The vacuum pump must be connected to the charge connections on high and low pressure side of the circuit.

Follow this procedure:

- Ø Discharge the circuit up to an absolute pressure of 35 mbar, then charge the cooling circuit with refrigerant gas up to reach a pressure of about 1 bar;
- Ø Repeat again the operation as described above reaching an absolute pressure of 35 mbar;
- Ø Repeat the above operation for the third time reaching the minimum absolute pressure as possible.

This operation allows to remove up to 99% of the polluting substances.

## C) REFRIGERANT CHARGE

Follow this procedure:

- Ø Connect the refrigerant gas cylinder to the male charge connection 1/4" SAE placed on the liquid line, letting some gas go out to remove the air in the connection pipe;
- Ø Turn the cylinder upside down and charge the liquid up to reach 75% of the total charge;
- Ø Now connect to the charge connection on the suction line and, keeping the cylinder upright, complete the charge till the temperature of the liquid pipe before the filter is lower than 7-8°C for the chiller (4°C for the heat pump) compared to the temperature shown on the refrigerant manometer for the discharge pipe.

### 5.6.3 Check of the setting up

The setting up must be checked while the unit is working in conditions as close as possible to the nominal ones.

Make sure:

- Ø The thermal load is adequate;
- Ø The water capacity and the evaporating and condensing water temperatures are close to the nominal ones.

Check the gas charge: the charge will be complete when, after 10 minutes of operation in nominal conditions, no bubbles are shown in the liquid sight glass.

Check the gas overheating on the compressor intake as shown below and, if necessary, set the thermostatic valve. While the unit is working in nominal conditions, connect a manometer on the low pressure side. Check the gas temperature on the compressor intake (Pict. 22) by means of a thermometer (Pict. 23).

The overheating intake value is given by the difference between the temperature shown on the thermometer and the saturation temperature (dew value for mixture) corresponding to the pressure shown on the manometer. If overheating is higher than 10°C, the thermostatic valve must be opened, while if it is lower than 5°C the valve must be shut off (Pict. 24 cap removal and Pict. 25 opening adjustment).

Valve adjusting operations must be always carried out with caution, turning the adjusting screw only half turn each time; wait for few minutes before every new adjustment in order to allow the unit to reach steady conditions.



Pict. 22



Pict. 23

Gas: R407C  
Suction Temp. 7°C  
Suction Pressure: 3,9 bar = +2°C  
Overheating: 5K



Pict. 24



Pict. 25



The thermostatic valve adjustment is a very delicate operation, therefore it must be carried out by a skilled technician..

## 5.7 Precautionary planned maintenance

## List of operations

	Every 6 months	Every year
Check of cooling lines and of their insulation		X
Compressor noise level check	X	
Electric connection tightening check	X	
Contactors status check	X	
Check of conductors insulation status		X
Check of evaporator water temperature difference	X	
Liquid sight glass check	X	
Electric absorption check	X	
Working pressures check	X	
Unit general conditions check		X
Probes setting check	X	
Set parameters check		X
Refrigerant filter pressure drop check		X
Safety valve check		X
Safety pressure switch check	X	
Electric protections check	X	
Thermostatic valve check		X
Check of air presence in the hydraulic circuit	X	
Check of condenser water temperature difference	X	
Check of condenser cleaning condition		X

### 5.7.1 Remote condenser coils cleaning (on the floor and under coverings)

Use a stiff-bristle brush and the necessary equipment; the use of an industrial vacuum cleaner may facilitate this operation.

Disconnect the unit from the power supply by opening the main switch,

- b. Remove the protection grid from the coil (if present),
- c. Brush the coil from the top to the bottom, being careful not to damage the fins.
- d. Accompany the brushing with the hoovering.
- e. Remove the dust and the down gathered..



Do not use compressed air (it might damage the fins) or water (it might cause scale).

### 5.7.3 Check of the hydraulic circuit and expansion vessel pressure

The hydraulic circuit pressure is determined by an expansion vessel and it is signalled outside the unit through a manometer. The pressure shown on the manometer must range between 0,15 and 0,30 MPa (1,5 and 3,0 bar).



The manometer and the expansion vessel complete of water charge valve (visible on the picture below the manometer) are supplied on the unit when pump and/or buffer tank are present as well.; if they are not present, manometer and expansion vessel must be installed at customer care.

### 5.7.4 Check of lubricant leaks - lubrication oil pressure

A lubricant oil leak in a cooling circuit is always accompanied by a refrigerant leak, therefore this check allows to detect possible leaks in advance. The inspection is visual-type and it is sufficient to light the areas to be checked by means of a good electric torch. All piping fittings and joints (welded and not welded) must be checked since they are more subject to vibration; if some oil is detected, contact the closest After Sale Centre for intervention. The lubrication oil pressure must be checked through the appropriate manometer (when present); the oil pressure must always be at least 0,15 MPa (1,5 bar) higher than the value shown on the low pressure gauge (L.P.).

### 5.7.5 Vibrations check

The cooling circuit is composed of several rotating parts (fans, compressors, pumps, etc) equipped with bearings and they are balanced at the beginning; excessive vibrations, scrapings, strikings, irregular noises such as whistles and creakings are all signals of mechanical troubles which might even generate serious and dangerous damages. The inspection must be performed while the unit is working and with the protection covers closed; in case of trouble, contact the closest technical service centre.

### 5.7.6 Check of terminals tightening

The vibrations the unit housing is subject to (and the electric box by transmission) can loosen the electric terminals thus causing malfunctionings; therefore, open the unit main switch and tighten all terminals screws; eventually, if it is always the same terminals to be loosened, contact the After Sales Service of EMICON A.C. S.p.A to report the fact.

### 5.7.7 Check of the water flow switch

The water flow switch takes the water pressure difference on exchanger's inlet and outlet. If the pipe marked with a white arrow clogs due to air presence or dirty (or roughly bends and then throttles) the switch may fail while sensing the pressure variation downstream with consequent system shutdown. Check the status of the pipe, its cleaning, check the connections are not leaking and vent the possible air.

25

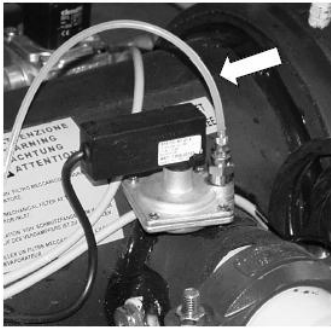

Pict. 30

#### 5.7.8 Check of the gaskets on the centrifugal fans discharge

The centrifugal fans discharge is connected to the external skirt by means of a flexible gasket; the gasket must not be damaged and must not let air pass through. In this case, its replacement is necessary, therefore contact EMICON A.C. S. p. A. After Sales Service..

#### 5.7.9 Compressors oil level check

Both scroll and semi-hermetic compressors are equipped with sight glasses to check the oil level.



WHILE CHECKING THE OIL LEVEL ALWAYS MAKE SURE THE FAN SECTION IS NOT OPEN

Oil level must be checked while the unit is working in steady conditions (therefore, after at least 15-20 minutes of operation). The oil level must be compared with the instructions shown on tags close to the sight glass; however, at least a quarter on the bottom of the sight glass must show the oil. An excessive presence of foam means that the thermostatic valves are not set up properly.

In case of trouble, contact EMICON A.C. S.P.A. After Sales Service.

#### 5.7.10 Insulation condition check

All low temperature parts are heat insulated by means of muffs or of shaped plates to eliminate or reduce any heat leak which can cause a cooling capacity reduction as well as condensing phenomena or ice formation (which can be dangerous since in some conditions they can cause mechanical breakings). The check is of visual type; the insulation must not be damaged, detached from the supports or cracked. Bear in mind that in time the surface of insulating materials tends to slightly flake off without jeopardizing the insulation feature. Cracks, cuts or detachments must be repaired immediately by sticking or taping properly.

#### 5.7.11 Supports and bearings check

While making the check, the unit main switch must be open ("0" position) and locked. The padlock key must be kept by the person in charge of the check



All rotating parts are equipped with supports and bearings. Usually these parts do not need any maintenance and/or lubrication as they are a long-life type. A direct check of these parts is only possible on fans by rotating manually the fan wheel: its movement must be fluid, with no blockings or creakings and it must not show any lubricant leak. If any of the mentioned cases occurs, contact EMICON A.C. S.p.A. After Sales Service for repairing it.



### 5.7.12 Humidity check of cooling circuit

Humidity inside the cooling circuit can cause many troubles (ice formation inside the expansion valve, acidification of compressors oil, etc.), therefore it is important to intervene immediately if this problem occurs. The cooling circuits are equipped with a light able to signal when humidity is present in the circuit; the sensor material located at the centre or on the border of the sight glass is bright green to signal a dry circuit or yellow to signal a wet circuit. On the sight glass the two referring colours for each status (dry / wet) are shown. If foam or bubbles can be seen through the sight glass, the refrigerant charge could be insufficient. This could be a sign for a refrigerant leak, then it is necessary to inform EMICON A.C. S.p.A After Sales Service. If humidity is detected inside the circuit, contact immediately EMICON A.C. S.p.A After Sales Service for repairing it..

### 5.7.13 Check of supply continuity to the crankcase heater



The unit main switch must be open ("O" position).

The compressors crankcase heater is essential to keep the oil free from refrigerant parts which otherwise might lead to possible seizure of compressor; the check must be performed by a common continuity tester checking there is supply continuity to the terminals after unplugging one of them from the terminal board. In case a supply interruption is detected, contact immediately EMICON A.C. S. p. A. After Sales Service for the shipment of the spare part of for the repair operation.

### 5.7.14 Regulation of overload protection relays

All electric motors are protected against overcurrent to prevent damage from over-loading the motor; for this reason, it is possible to install a regulation system which can interrupt current in case of overload or damage

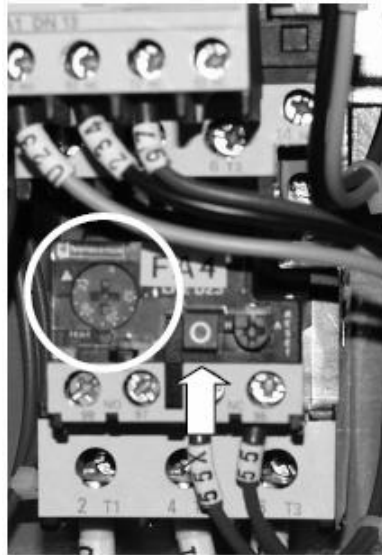

Pict. 17



Pict. 18

The pictures show two different types of remote control switches: the one shown on (Pict. 17), is equipped with a detached protection, while the one shown on picture 18 is equipped with an incorporated protection (automatic circuit breaker). In both cases the regulation of the power-off switch value (maximum absorbed current per each motor phase) is performed by rotating the small wheel shown inside the white circle by means of a screwdriver till the referring triangle is in correspondence of the desired set value.



The maximum power-off value that can be set must not be higher than the absorbed current value shown on the electric motor tag..

When powered, the remote control switch can be opened by pressing the button indicated by the white arrow..

### 5.7.15 Replacement of protection fuses

Some parts of the unit circuits are protected by fuses enclosed in appropriate housings.



THE THE REPLACEMENT OF FUSES MUST BE EXCLUSIVELY PERFORMED WITH THE MAIN SWITCH OPEN.

#### Cartridge fuses

To replace the fuses, open the fuse holder, pull straight out on the small black handle down, remove the fuse/s and replace it/them with a new fuse having the same characteristics. Before replacing it, check the interrupting current rating of the broken fuse.



THE REPLACEMENT SHOULD ALWAYS HAVE THE SAME RATING AS THE ORIGINAL, SINCE A HIGHER RATING COULD CAUSE OVERHEATING, DAMAGE, FIRE.

#### Blade fuses

This kind of fuse is designed for higher interrupting ratings and it must be absolutely replaced by using an appropriate device. Never try to replace it by using inappropriate devices: possible damage to the fuse holder and wounds to the hands may happen. Proceed as per the following instructions

Pict. 19



Pict. 20



1. Remove the fusebox cover.
2. Take the extractor tool "2" located inside the electrical panel.
3. Insert the puller into the fuse spring clips (see the white circle on Picture 19) and pull the extractor down till the clips are released.
4. Pull the extractor horizontally and firmly towards you; (any different movement could detach the cover from the fuse holder).
5. Press the button on the puller to remove the fuse (see Picture 22).
6. Insert the new fuse onto the puller and put it back into the fuse holder.
7. Release the puller by pressing the button.

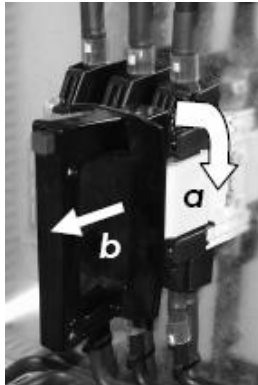

Pict. 21



Pict. 22



DO NOT TOUCH THE FUSE WITH NAKED HANDS: THE TEMPERATURE OF THE SURFACE COULD BE VERY ELEVATED AND COULD CAUSE BURNS.

#### 5.7.16 Replacement of condensing fan motors



While making the check, the unit main switch must be open ("0" position) and locked. The padlock key must be kept by the person in charge of the check.

There are two types of fans: axial and centrifugal. In case of axial fans, being external-rotor type, it is recommended to replace completely the damaged fan after disconnecting the power supply (take due note of the original wiring). Mount the fan on its supports and ensure the blades do not scrape the blade guard and the supports, re-connect the electric wirings, check the rotation direction (if needed, reverse two phases). In case of centrifugal fans, after disconnecting the motor from the power supply, unscrew the fixing screws and remove it in the same way as described for the belts replacement (see par. 5.7.12); remove the pulley from the shaft by means of an extractor, after unscrewing the fixing dies.

The motor pulley is of adjustable type. If to unscrew the fixing dies the regulation must be changed, it is necessary to mark the original position with an indelible felt-tip pen and count the turns of the mobile part so that it is possible to reestablish exactly the original regulation once the operation is completed. Remove the protection paint from the shaft and from the new motor key (use a brush, solvent and some cloths); clean the inside part of pulley, lubricate with oil and install the pulley on the new motor making sure not to force the coupling. Once the pulley is entered into the shaft, insert it completely by means of a hard rubber mallet and block it definitely with the appropriate dies. Mount the motor and if needed reestablish the original pulley regulation and tighten the belt (see par. 5.7.12). Reconnect the motor and check the rotation by a short impulse given to the remote control switch after energizing it. If necessary, change the electric connection (inverting the connection of two phase cables) after disconnecting the power supply. Close the protection covers.

### 5.7.17 Replacement of compressors crankcase heaters



While making the check, the unit main switch must be open ("0" position) and locked. The padlock key must be kept by the person in charge of the check.

The type of crankcase heater installed varies according to the type of compressor, if scroll or semi-hermetic; scroll compressors need to be installed a tubular heater (see picture), while semi-hermetic compressors need a cartridge heater (see drawing). The heater position may vary following the compressor type and model, anyway it is always located on the underside of the compressor crankcase.



Pict. 23

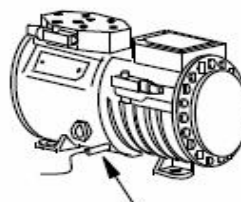

Pict. 24

The tubular heater must be replaced by unscrewing the fixing screws (position indicated by the arrow in the picture) so that it can be easily removed; mount the new heater in the same position of the replaced one and push it against the compressor housing. The cartridge heater must be replaced by removing it from its location and installing in its place the new heater. In order to improve the heat transmission, use conductive paste or oil.



The cartridge must not stick out from its location; the protruding part may overheat and stop working.

### 5.7.18 Electrical cables check

The check is visual: the electrical cables must be not damaged or show abrasions, cuttings or overheating signs. In this case, replace them immediately.

### 5.7.19 Contactors status check

This operation must be performed by an expert electrician able to dismantle and re-install the remote control switches without damaging them. In case of blazed or blackened auxiliary switches or the whole remote control switch, make sure the contactor interrupting power is adequate to the power it runs.

## 5.8 Special maintenance operations

The operations listed here below must be performed only by skilled service personnel equipped with the suitable equipment and only when the unit is stopped and disconnected from the power supply

	Operation	Frequency
1	Filling up of compressor oil	when necessary
2	Replacement of crankcase oil	when necessary
3	Replacement of compressor valves	when necessary
4	Check of cooling group performance	when necessary
5	Setting of cooling group pressure switches	when necessary
6	Replacement of cooling group pressure switches	when necessary
7	Replacement of filter cartridge	when necessary
8	Replacement of dehydrating filters	when necessary
9	Setting of cooling circuit valves	when necessary
10	Replacement of the cooling circuit valves	when necessary
11	Filling up / replacement of refrigerant	when necessary
12	Compressor replacement	when necessary
13	Replacement of compressor lubricant pump	when necessary
14	Heat exchanger replacement	when necessary
15	Circulating pump replacement	when necessary

For all the above mentioned operations and for any other operations not completely described on this manual, it is necessary to contact EMICON A.C. S.p.A. After Sales Service. To guarantee the unit a long operation life and to keep it always in the best efficiency conditions and to increase its service reliability, it is highly recommended to contact EMICON A.C. S.p.A. After Sales Service to draw up a maintenance contract

### 5.8.1 Process Water

The process water cooled by the unit circulates into a closed circuit and for special applications it may be mixed with anti-freeze substances. The fluid temperature is usually over +5°C and the unit has internal control devices which prevent it from freezing with consequent damage of the gas-water exchanger. The process water must be regularly checked in order to avoid:

1. being polluted with substances which may damage the cooling circuit components (for ex. If the water is used to cool chemical distillers which produce corrosive liquids, it may happen that the water becomes corrosive itself because of troubles in the exchange circuit supplied).
2. acidification due to the decomposition and toning of the antifreeze substances used in the applications with working temperatures below +5°C

## 6. DISMANTLING

When the unit has to be dismantled, drain the cooling circuit and collect the refrigerant gas by means of an adequate receiver, in order to protect people and environment.



Never release the gas contained in the cooling circuit in the environment.

When dismantling the unit or when replacing the compressor, carefully collect the oil compressor and deliver it to an authorized company for oil disposal



Never release the oil compressor in the environment.

# USE AND MAINTENANCE MANUAL

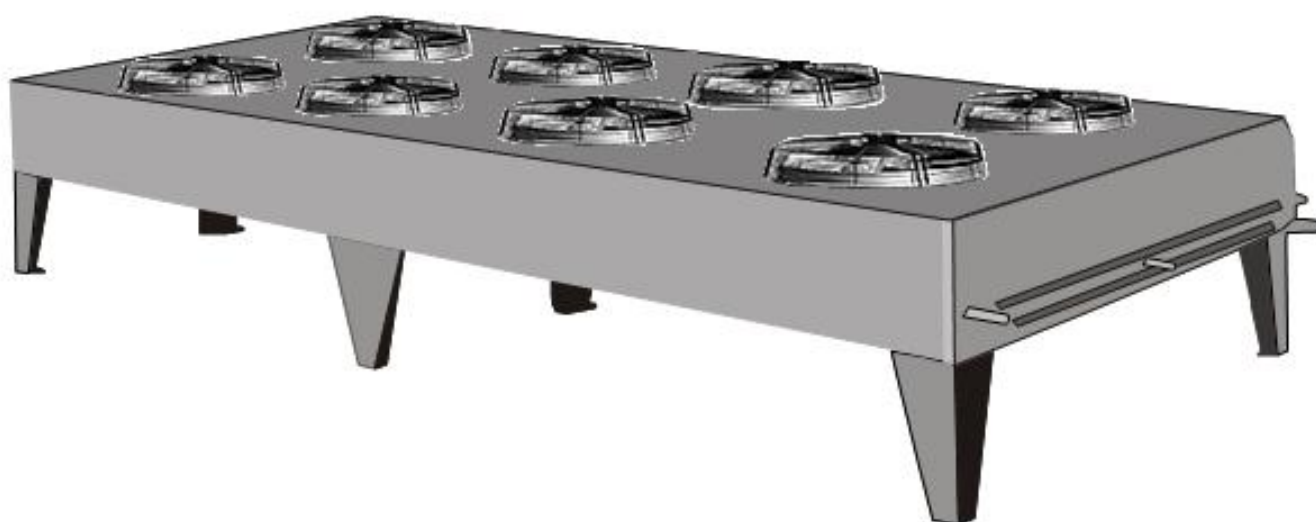

## AIR CONDENSERS

With axial fans  
CR/CRS/CRU

## TABLE OF CONTENTS

1	WARNINGS .....	Pag. 47
2	TRASPORTATION.....	Pag. 48
3	CHECKS FOR A CORRECT INSTALLATION .....	Pag. 48
4	WARNING FOR A CORRECT PLACING.....	Pag. 49
4.1	Technical Specification .....	Pag. 49
4.2	Placing .....	Pag. 49
4.3	Electric connections .....	Pag. 49
5	INSTALLATION .....	Pag. 50
6	GENERAL MAINTENANCE.....	Pag. 51



# 1 - WARNINGS

Keep this technical manual all along the condenser's life.  
Read carefully the manual before the installation and before any operation on the unit.

Use the condenser only for the use it has been designed for: the manufacturer disclaims all responsibility in case of misuse.

The interpreting key for the condenser initials is described here below:

CR = Remote condenser with axial fans

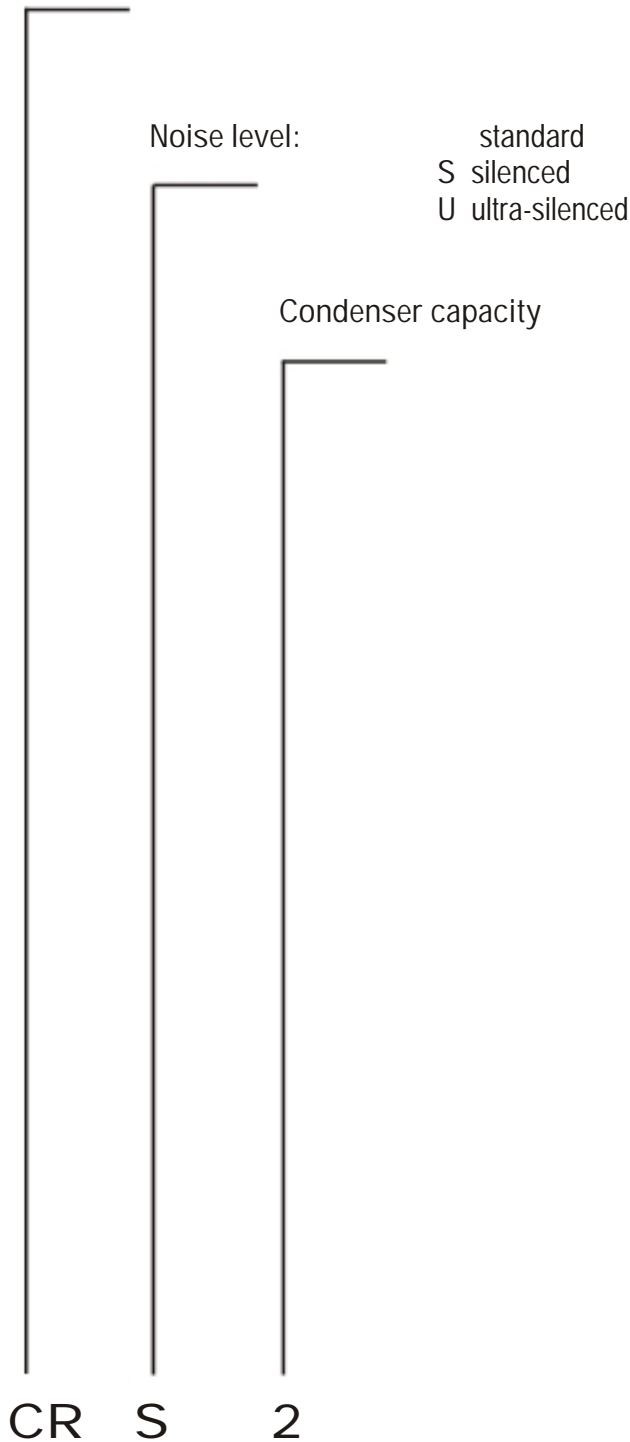

## 2 - TRANSPORTATION

During the transportation, avoid to press the packing improperly and always keep it in the position indicated on it.

Unpack the unit as close as possible to the place where it has to be installed. Once unpacked, avoid to hit the components.

During the air conditioner installation and handling, wear the appropriate gauntlets in order to avoid to be hurt by the unit cutting parts (ex. Fins).

## 3 - CHECKS FOR A CORRECT INSTALLATION



In order to avoid any damage during the lifting operation, use a beam and connect it to all available hooks as shown in Picture 1.

- a) Make sure the floor and the structures can bear the unit weight;
- b) Do not install the unit in closed spaces;
- c) Leave an adequate free space to allow a correct air suction and discharge and an easy maintenance (see Par. 4.2);
- d) Make sure the condenser is properly fixed to the supporting floor;
- e) Check the electric power supply fits with the motor-fans characteristics;
- f) Condensers are equipped with axial motor-fans, therefore they are not appropriate for being ducted or for bearing higher available pressure;
- g) Make sure the operating conditions (temperature and pressure) are conform to the ones estimated in the plan;
- h) Make sure all electric connections are in compliance with existing local regulations;
- i) Only qualified personnel is allowed to have access to the unit for any required operation, in accordance with the laws in force;
- l) During the installation, suitable fixing and supporting systems for the unit must be foreseen.

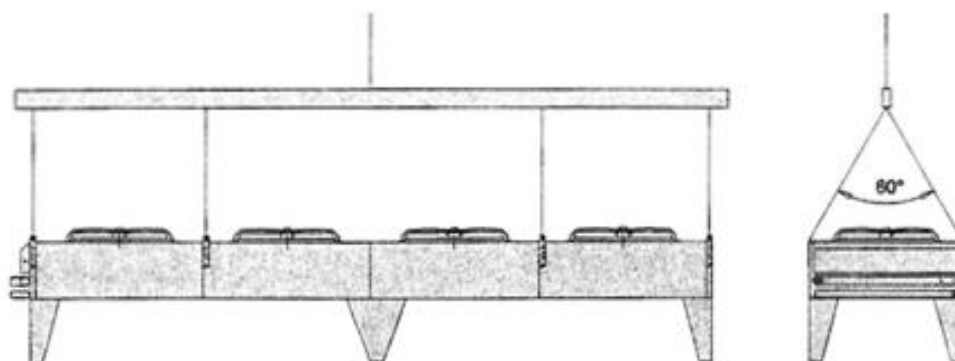

Picture 1



Before any maintenance operation, make sure the electric power supply is disconnected from the main source: the electric parts might be connected to an automatic control

## 4 - WARNINGS FOR A CORRECT PLACING

### 4.1 Technical specification

See the attached technical specification sheet.

### 4.2 Placing

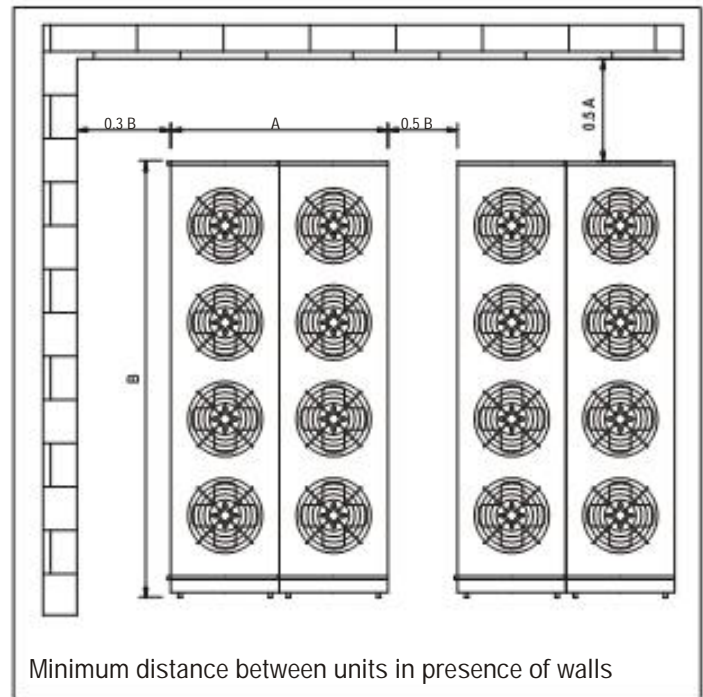
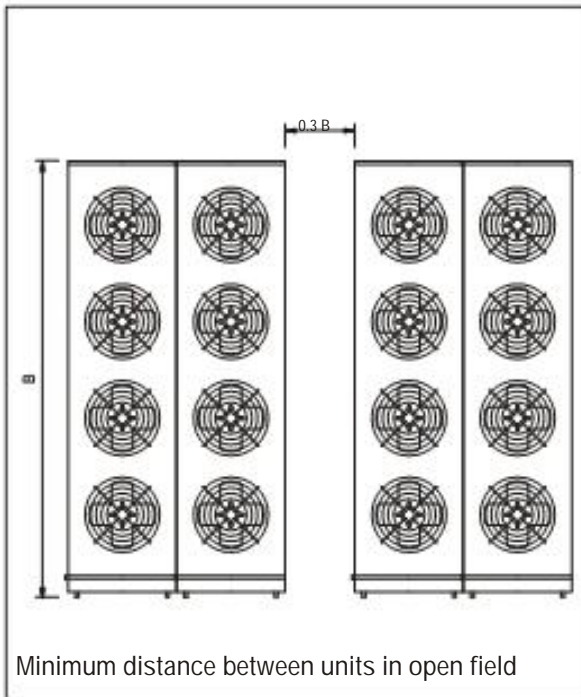
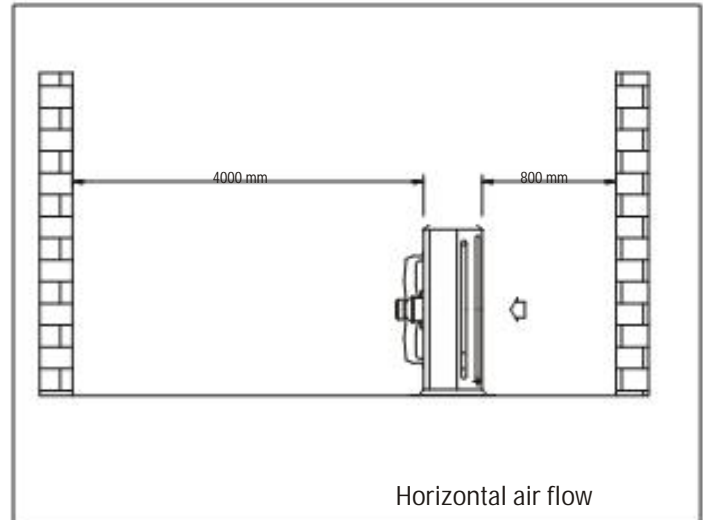
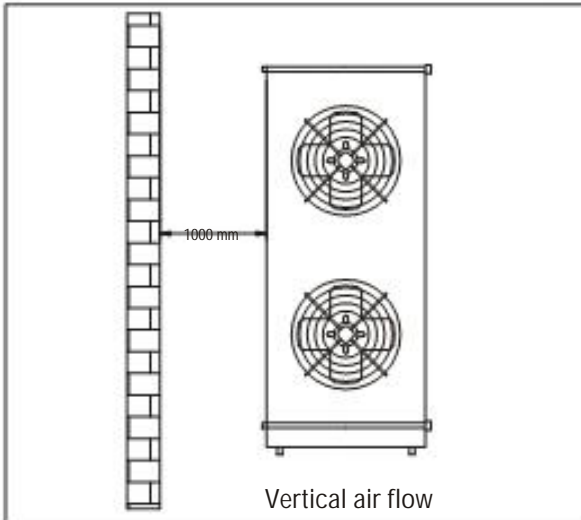

### 4.3 Electric connections

See the attached wiring diagram.

The thermal contacts are activated following the temperature and they are installed in the motors windings: when the temperature exceeds the maximum allowed permanent value, an electric contact is opened.

Carefully follow the attached wiring diagram to avoid any damage to the motor. Before employing an rpm regulation system, check if it is compatible with the motor: non-compatible systems can cause noise and damages. Emicon A. C. S.p.a. disclaims all responsibility for the performance of units equipped with a regulation system.

## 5 - INSTALLATION

For a correct installation, follow the tips here below:

- 1) Size properly the pipes in order to avoid as much as possible a pressure drop and a reduction of refrigerant speed, since both factors are essential for the oil drag. If necessary, an oil separator must be installed (3).
- 2) In case the discharge line goes through rooms where people normally live, install both a vibration damper (1) and a silencer (2) as close as possible to the compressor, on the discharge line.
- 3) Do not convey the air flow directly on a surface having a reflecting power or able to increase the condenser noise level.
- 4) Do not reverse for any reason the refrigerant inlet and outlet collectors.
- 5) Place the condenser preferably in a position where the coil has a minimum direct exposure to sun radiations since they could change the condensation pressure.
- 6) In all installations, make sure the airflow does not collide with other currents of air going in the opposite direction.
- 7) Strictly follow the local regulations in force.

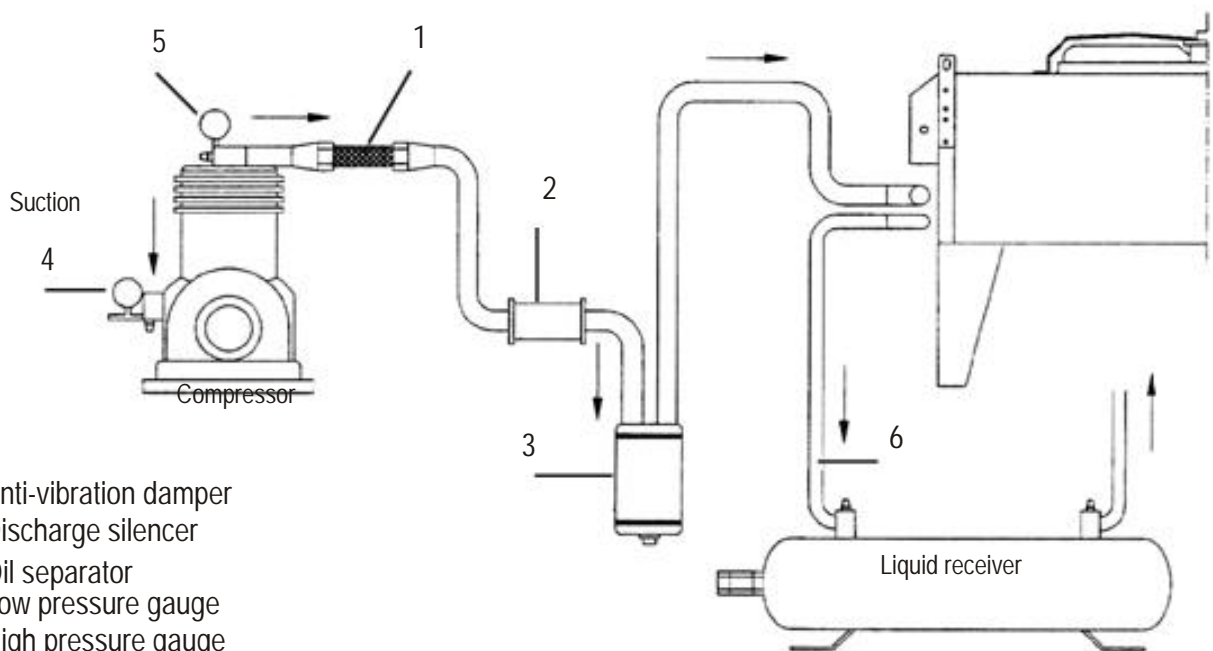

1. Anti-vibration damper
2. Discharge silencer
3. Oil separator
4. Low pressure gauge
5. High pressure gauge
6. A slope not lower than 1% must be foreseen between the outlet collector and the liquid receiver

The following table shows the necessary quantity of refrigerant for a correct charge of the different models of remote condensers.

REMOTE CONDENSER			REFRIGERANT CHARGE
CR	CRS	CRU	
8	/	/	0,8 kg
11	7	/	1,5 kg
14	10	/	1,2 kg
18	13	/	1,8 kg
27	22	18	2,9 kg
30	25	20	3,8 kg
36	29	23	4,5 kg
45	/	28	6,0 kg
46	35	/	7,5 kg
49	42	32	5,7 kg
53	/	/	7,6 kg
59	57	43	9,0 kg
71	67	51	12 kg
90	85	68	14 kg
97	/	/	15 kg
/	99	74-87	18 kg
/	/	98	24 kg

## 6 - GENERAL MAINTENANCE

Check periodically the fasteners, the electric connections and the connections to the cooling system.

Clean periodically the unit to avoid any accumulation of harmful substances. It is advisable to use normal soapy water. Do not use solvents, aggressive, abrasive or ammoniac agents.



Only expert and qualified personnel can carry out the general maintenance.

# DICHIARAZIONE CE DI CONFORMITÀ EC DECLARATION OF CONFORMITY CE-KONFORMITÄTSERKLÄRUNG DECLARATION CE DE CONFORMITÉ

Il Fabbricante

The Manufacturer

Der Hersteller

Le Fabricant

**EMICON A.C. S.P.A.**

via A. Volta, 49

47014 Meldola (FC)

tel. (+39) 0543/495611

fax. (+39) 0543/495612

 e-mail [emicon@emiconac.it](mailto:emicon@emiconac.it)
**DICHIARA**
*che la macchina*
**DECLARES**
*that the machinery*
**ERKLÄRT**
*daß die Einheit*
**DECLARE**
*que l'unité*
**Modello**
**Model**
**Modell**
**Modèle**
**Matricola**
**Serial Nr.**
**Serienr.**
**N.ro de série**
*è conforme a tutte le disposizioni pertinenti delle direttive*
**2004/108/EC**
*in quanto è stata progettata, costruita e collaudata in accordo con le seguenti Norme*
**EN 61000-6-1**
**EN 61000-6-2**
**EN 61000-6-3**
**EN 61000-6-4**
*fulfils all the relevant provisions of the directives*
**2006/42/EC**
*because it has been designed, manufactured and tested according to the following Standards*
**EN ISO 12100-1**
**EN ISO 12100-2**
*den folgenden Vorschriften entspricht*
*da sie in Übereinstimmung mit den folgenden Normen geplant gebaut und getestet wurde*
*est conforme aux dispositions*
**2006/95/EC**
*étant l' appareil conçu, réalisé et testé dans le respect des normes suivantes*
**EN 60204-1**
**EN 60335-1**
**EN 60335-2-40**
**EN 60439-1**
**AUTORIZZA**
*a costituire il Fascicolo Tecnico.*
**AUTHORISES**
**Romano Santucci**

via A Volta, 49

47014 Meldola (FC)

*to compile its Technical File.*
**AUTORISIERT**
*die technischen Unterlagen zu erstellen*
**AUTORISE**
*à réaliser le dossier technique.*

Meldola, \_\_\_/\_\_\_/\_\_\_\_\_

Romano Santucci

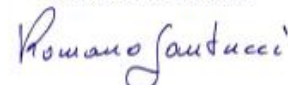

Technical Manager



Emicon A.C. S.p.a. reserves the right to make changes to tis products without any prior notice





Emicon A.C. S.p.a. Via A.Volta 49 Meldola Tel. +39 0543 495611 Fax +39 0543 495612